



Antenna **G**enius Manual

Version 3.0.4, rev 01

Table of Contents

1. WELCOME!	3
2. SPECS & FEATURES	3
3. LEGAL	4
3.1. Radio & television interference	4
3.2. European Community CE conformity	4
3.3. Product updates	5
3.4. Limited warranty	5
3.5. Trademarks	5
4.1. Multiple control options	6
4.2. FlexRadio Integration	6
4.3. SO2R and multi-op with a single FLEX-6000	6
5. HOW IT WORKS	7
5.1. Tech	7
5.2. Hardware	7
5.3. Software	7
5.4. FlexRadio Ecosystem	7
6. ONLINE RESOURCES	7
7. WHAT COMES IN THE BOX?	8
8. HARDWARE	8
8.1. Bottom panel	8
8.2. Top panel	9
8.3. Where to put it?	9
8.4. DC power connection	10
8.5. Network cabling	11
8.6. DIP Switch configurations	12
8.7. LAN control	13
Click Save ad Reset	15
8.8. Interface Genius control	15
Click Save ad Reset	16
8.9. BCD control	16
8.10. Pin-to-Port control	17
You can use the 4O3A manual controller for this purpose:	18
9. ANTENNA GENIUS™ APP	18
9.1. Initial set-up	19
9.1.1. Confirm DIP switches	19
9.1.2. Download and install the AG Windows App	19
9.1.3. Using DHCP to set the network address	22
9.1.4. Setting the network address manually	23
9.1.5. Launch the Windows App	23
9.1.7. Programming antenna data	24
9.2. Device Information	24
9.3. Is your firmware up-to-date?	25
9.4. AG Control Window programming	27
9.4.1. Full duplex 'in band' operation	30
This feature is still not implemented and will be released as a software update!	30
10. OPERATION	30
10.1. Local (LAN) operation	30
10.2. Internet (WAN) remote operation	31
11. ADDITIONAL FEATURES	31
11.1 Stacking multiple AG's into a superswitch	31
11.2 Custom Band Configuration	35

11.3 Output Module Relay Control.....	37
11.4 PTT sense.....	43
11.5 Auto connect on startup.....	44
12. PHOTO GALLERY.....	44
13. CHANGELOG.....	44

1. WELCOME!

Congratulations on your purchase of an Antenna Genius™ 8x2 Plus Network-Enabled (TCP/IP) High-Isolation Antenna Switch, a member of the 4O3A Genius System™ advanced station automation line including Rotator Genius™, Station Genius™, and Interface Genius™. More information on these products can be found at:

<http://www.4o3a.com/index.php/products/station-automation/>

GENIUS TIP! Antenna Genius™ is sometimes abbreviated as “AG” in this document.

AG is at home in all types of ham shacks: contest stations extravagant and modest, from single op to SO2R to full blown Multi-Multi, DXers, remote operators controlling their station from their living room via LAN or over the Internet from a hotel room thousands of miles away, to anyone wanting a better organized and more efficient station.

2. SPECS & FEATURES

Manufacturer	4O3A Signature™ by Sky Sat d.o.o.
Model	Antenna Genius™ 8x2 Plus
Functionality	8 antenna 2 radio RF matrix switch controlled via TCP/IP (LAN or WAN), BCD, or +12 VDC pin-to-port
RF connectors	UHF female (SO-239) standard, N female available by special order
Power handling	→ 3,000 Watts ICAS (SSB/CW) for 5 minutes @ 1.5:1 VSWR @ 30 MHz → 3,000 Watts ICAS (SSB/CW) for 3 minutes @ 1.5:1 VSWR @ 50 MHz
Ports	→ RJ-45 (LAN) → two DE-15 VGA-type (BCD band data or +12 VDC pin-to-port)
Network	100Base-T Fast Ethernet (100-Mbps), DHCP or manually-assigned network address, TCP/IP
Power consumption	300 mA @ 13.8 VDC
Frequency range	DC through 55 MHz
Port-to-port isolation	→ 90dB between ports worst case @ 14 MHz → 80dB between ports worst case @ 30 MHz → 70dB between ports worst case @ 50 MHz
CPU	Microchip Technology 32-bit PIC processor
Automation	Windows App, FlexRadio Systems SmartSDR API, Interface Genius™ IG-M, BCD, Pin-to-Port
Features	→ hardware interlock prevents two radios connecting to same antenna → unselected antenna ports grounded → LEDs indicate antenna ports in use → firmware updates via LAN
Case	rugged stainless steel chassis with wall mount flanges top and bottom
Dimensions	6.75” W x 13.25” H x 3.25” D including mounting flanges (21 x 17 x 6 cm)
Net weight	approx. 4.4 lbs (approx. 2 kg)

3. LEGAL

3.1. Radio & television interference

(FCC Part 15 - §15.21 and §15.105)



This equipment has been tested and found to comply with the limits for a Class B digital device, pursuant to part 15 of the FCC Rules. These limits are designed to provide reasonable protection against harmful interference in a residential installation. This equipment generates, uses and can radiate radio frequency energy and, if not installed and used in accordance with the instructions, may cause harmful interference to radio communications. However, there is no guarantee that interference will not occur in a particular installation. If this equipment does cause harmful interference to radio or television reception, which can be determined by turning the equipment off and on, the user is encouraged to try to correct the interference by one or more of the following measures:

Reorient or relocate the receiving antenna.

Increase the separation between the equipment and receiver.

Connect the equipment into an outlet on a circuit different from that to which the receiver is connected.

Consult the dealer or an experienced radio/TV technician for help.

You may also find the following FCC booklet helpful: *"How to Identify and Resolve Radio-TV Interference Problems"* available from the U.S. Government Printing Office, Washington D.C. 20402. Info also available online at FCC.gov:

<https://www.fcc.gov/guides/interference-defining-source>

Changes and Modifications not expressly approved by the manufacturer or registrant of this equipment can void your authority to operate this equipment under Federal Communications Commissions rules.

3.2. European Community CE conformity



Sky Sat d.o.o. declares Antenna Genius™ 8x2 complies with the European Community EMC standards:

ETSI EN 300 330-1

ETSI EN 300 489-1

ETSI EN 300 489-15

CE compliance reports are available upon written request to Sky Sat d.o.o.

3.3. Product updates

Sky Sat d.o.o. reserves the right to make hardware and/or software product improvement or manufacturing changes without notice or any obligation to update units previously sold.

3.4. Limited warranty

This product is warranted to be free of defects in materials and workmanship for one year from the date of purchase. Sky Sat d.o.o. will repair or replace, at our option, any equipment proven to be defective within the warranty period. North American warranty work F.O.B. Force 12 Superstore, 784 Valley Court, Unit C3, Grand Junction, Colorado 81505-8722 USA. Europe and Rest of World warranty work F.O.B Sky Sat d.o.o., Ratiševina bb, Igalo 85347, Montenegro. Please contact the appropriate party for your region and obtain a return authorization (RA) number before returning any product for warranty service. RA number must be indicated on box used to return product for service.

This warranty is exclusive of abuse, misuse, accidental damage, acts of God or consequential damages, etc. Sky Sat d.o.o.'s liability shall not exceed the original purchase price of the product.

3.5. Trademarks

4O3A Signature™, Antenna Genius™, Rotator Genius™, Station Genius™, Interface Genius™, and 4O3A Genius System™ are trademarks of Sky Sat d.o.o.
FlexRadio Systems™ and SmartSDR™ are trademarks of Bronze Bear Communications, Inc. d/b/a FlexRadio Systems
PIC32™ is a trademark of Microchip Technology Inc.

All other products, company names, brand names, and trademarks are the property of their respective owners.

3.6. Copyright

This publication Copyright © 2015, 2016 by Sky Sat d.o.o. All rights reserved. May not be reproduced in part or in whole without Sky Sat d.o.o.'s prior written permission.

4. WHAT CAN ANTENNA GENIUS™ DO?

Antenna Genius™ 8x2 is a matrix antenna switch which can route eight antennas to two radios using a variety of control methods. Software and hardware interlocks - double protection - prevent the same antenna from being connected to both radios. This, along with AG's ultra-high port-to-port isolation help protect your radios from front end damage.

AG in action with SmartSDR @ W0LFA (**AG Always on top** option engaged):

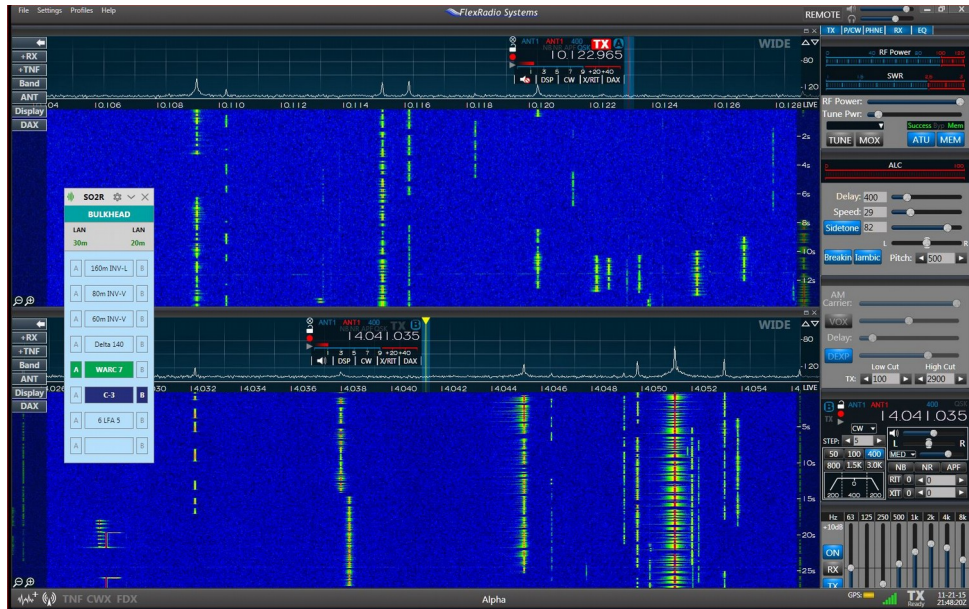

4.1. Multiple control options

You have five ways to control your AG:

1. FlexRadio SmartSDR API* over your network; AG will automatically follow two different Slice band selections (at present connected through the AG Windows app, direct connection between SSDR and AG is planned as a future capability to SSSDR & Maestro)
2. Manual band change from the AG Windows app connected via your network
3. Interface Genius™ (IG) connected to your radio(s) via a USB or serial port and connected to AG via LAN; IG will connect to pretty much any modern radio via its serial or USB CAT port
4. BCD (Binary-Coded Decimal) signals via the DE-15 VGA-style connector
5. +12 VDC “Pin-to-Port” via the DE-15 VGA-style connector

*Application Program Interface, technical protocols that enable third-party software programs to interact with an application

4.2. FlexRadio Integration

Automated antenna selection controlled by FlexRadio SmartSDR API. Elegant and powerful.

GENIUS TIP! 4O3A Genius System™ products are popular with FlexRadio users, so its only appropriate that *SmartSDR* be on intimate terms with a *Antenna Genius*™! At the time this manual was being written, there were plans to add direct Antenna Genius™ support in SmartSDR & Maestro. Presently, you can connect AG to SSSDR via the AG App.

4.3. SO2R and multi-op with a single FLEX-6000

AG's extreme port-to-port isolation is perfect for SO2R contesting with a single Flex rig! With AG, you can operate SO2R (Single Operator 2 Radio) with one radio using a single FLEX-6700 transceiver in full duplex mode, and soon, using the forthcoming FLEX-6000-PDC Controller/BPF, with FLEX-6300 and FLEX-6500 radios. In other words, the 'two radios' in SO2R are both inside your single Flex rig!

GENIUS TIP! All 4O3A Genius System™ products use standard TCP/IP protocols to communicate with each other and with other suitably-equipped devices. The 4O3A Signature team believes in open standards in ham radio and makes its APIs (library of commands) available freely to other manufacturers and software authors.

5. HOW IT WORKS

Antenna Genius brings together a powerful CPU, fast network interface, rugged, high power relays and a programming/control App that runs in all supported versions of Windows. We are confident AG is the best antenna switch you can buy.

5.1. Tech

AG is powered by a Microchip Technology PIC32 microprocessor, a 32 bit device. Why so much horsepower in an antenna switch? Advanced technology radios demand high-horsepower accessories! Also, the extra computing power enables the addition of new features via firmware updates in the future.

AG has 100BASE-T networking built-in. Based on the Ethernet standard, but ten times faster than 10BASE-T, it is often referred to as Fast Ethernet. Officially, the 100BASE-T standard is IEEE 802.3u. 100BASE-T devices will also work fine on older 10BASE-T networks albeit at slower speeds.

5.2. Hardware

AG uses high quality 16 Amp relays rated at 12,800 W DC and conservatively rated for 3,000 W RF at up to 50 MHz. AG's relays are used for RF switching and also for the hardware lockout that prevents two radios from being connected to the same antenna (there is also a software lockout for redundant protection). The design priority was maximum port-to-port isolation coupled with power handling 'headroom' - twice legal limit at high duty cycle - to enable reliable, long term operation.

5.3. Software

The AG App runs on all Microsoft-supported versions of Windows and is an integral part of the AG system. You will use the AG App for initial set up and programming of your AG and also for alternate antenna selection when you have more than antenna available for a particular band. The AG App can also serve as your AG control interface if you don't want automatic band selection controlled by FlexRadio Slice band changes.

5.4. FlexRadio Ecosystem

In the "FLEX-6000 Signature Series Ecosystem," the AG App collects frequency and other data directly from the SmartSDR (SSDR) API, a software-to-software connection performed inside your PC or over your LAN at very high speed. No RS-232 cables to set up, no "stop bits," nor lethargic baud rates. It is a truly modern, intelligent, and high speed solution.

AG will monitor any two SSDR Slices to determine the bands in use and use this data to select the appropriate antenna(s) for each Slice.

GENIUS TIP! You can use up to eight AGs on the same LAN.

6. ONLINE RESOURCES

4O3A Genius System™ owners have many online resources available to help them fully realize the capability of their Antenna Genius™, Rotator Genius™, Station Genius™ and Interface Genius™. At the time of writing (March 2016), Sky Sat plans on adding new AG features via firmware updates and FlexRadio Systems is planning on adding direct AG control capability to SmartSDR™ and Maestro™:

Documentation and software: current owners manuals, white papers, Apps, firmware, and changelog are available at:

<http://www.4o3a.com/index.php/support/downloads/>

4O3A Genius Devices Google Group:

<https://groups.google.com/d/forum/4o3a-genius-devices>

FlexRadio Systems Community: a great resource for anything related to FLEX-6000 Signature Series™, SmartSDR™ and Maestro™:

<https://community.flexradio.com/flexradio/>

EXPERT TIP! Join the 4O3A Genius Products Google Group to stay up-to-date, network with other users, and get helpful tips:

<https://groups.google.com/d/forum/4o3a-genius-devices>

7. WHAT COMES IN THE BOX?

When you unpack your AG box you should have:

- **Antenna Genius**
- Other items, such as **LAN, DC** and **coax cables**, are user supplied
- **Owner's Manual** (this document) and other documentation is available for free download from:
<http://www.4o3a.com/index.php/support/downloads/>

8. HARDWARE

EXPERT TIP! Read this and the following Software section carefully before changing any DIP switches or software settings.

8.1. Bottom panel

Bottom panel features:

- LAN: RJ-45 jack connects to your home/shack network (assumes you are using the network control option as most Flex users will be)
- LEDs: green LEDs indicate which B port antenna has been selected and red LEDs indicate which A port antenna is selected
- Two DE-15 VGA-type for users opting for BCD or +12 VDC pin-to-port control in lieu of network control, these are left unconnected if you are using network control (most FlexRadio equipped stations won't use these ports)
- 12VDC: connect your shack 13.8 VDC power supply here paying attention to proper polarity, anywhere from 12 to 14 VDC with at least 300 mA will be OK
- OM module: enables connecting the 16 relay output module for station automation
- DIP Switches: The side panel has 8 DIP switches for setting the operating mode configuration. AG can be controlled four different ways: (1) LAN, (2) BCD, (3) Pin-to-Port, and (4) 4O3A Interface Genius™. The control mode is set independently for Port A (Radio A) and Port B (Radio B) by the DIP switches. For example, Port A could be controlled over the network and Port B could be controlled by BCD signals.



8.2. Top panel

The top panel features a connector for stacking multiple AG units. This enables switching between 16, 24 or 32 antennas.

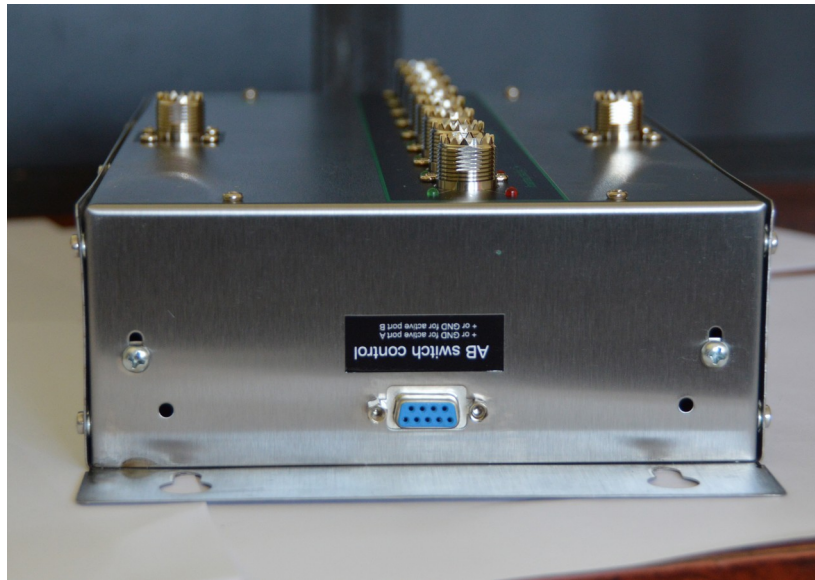

8.3. Where to put it?

Most users will install AG near their station bulkhead, the location where their antenna feed lines, AC mains, DSL, cable TV, and/or other cables enter the shack and where the single point ground system nexus is located (you do have a single point ground system, don't you?). Locating AG at your bulkhead or other remote location means only three cables need to be run to the station operating position, coax for the A and B radios and a Cat5e (or higher) Ethernet cable for the LAN (if not using LAN, you will need a pair of control lines, one for Port A and for Port B).

Here is the bulkhead-sited AG @ W0LFA prior to connection of coax lines and ground connection:

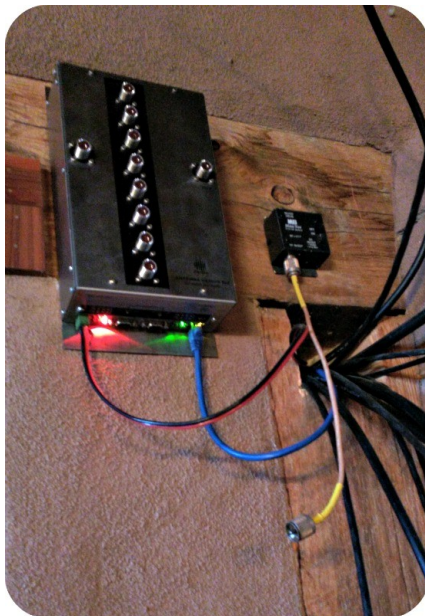

AG can also be installed at the operating position or outdoors. If the later, install AG in an outdoor NEMA-rated enclosure and make sure it has a 'weep hole' at the bottom to allow air circulation and to let moisture out.

EXPERT TIP! Reduce station clutter by mounting your AG near your station cable entrance “bulkhead.” Slots for such mounting are provided on the top and bottom of the OM case.

AG is a 100BASE-T network device using standard TCP/IP protocols, it is therefore subject to the usual 328-foot (100m) LAN cable run limitations per TIA/EIA 568-5-A. If longer runs are required, the use of intermediate active hardware such as a repeater or switch will be necessary. Cat5e cable is recommended, and higher-rated cables such as Cat6 are also OK.

EXPERT TIP! For outdoor UTP (Ethernet) cable runs, be sure to use outdoor-rated cable including UV-resistance properties if located in direct sunlight.

4O3A Signature encourages all amateur radio operators to employ single point ground systems for both protection from lightning induced power surges and also for RFI mitigation. A good source for information on this topic is the ARRL Handbook, updated annually and available from the ARRL Bookstore:

<http://www.arrl.org/>

Another excellent resource for station grounding information and RFI mitigation are several documents written by Jim Brown, K9YC, available for free download at:

<http://www.audiosystemsgroup.com/K9YC/K9YC-old.htm>

AG is a computer and thus its electronics will generate some heat. Also, the relays and other components will generate heat when under load. Make sure there is adequate clearance and airflow around the AG cabinet sides and top in its installation position.

8.4. DC power connection

Connect a DC power cable from your station 13.8 VDC power supply (anywhere from 12 to 14 VDC is OK, your shack DC power supply is likely 13.8 VDC) to the outlet marked 12VDC on the bottom panel. We recommend using a DC fuse such as those provided on the popular RIGrunner and similar DC power distribution units (you can use the 1 Amp blade fuse that comes with RIGrunners). If you don't have a RIGrunner, we strongly suggest you place a 1 Amp DC fuse in series with the hot side of your DC power cable.

The terminal block DC power connector on AG uses two screw terminals to secure up to AWG #15 wire (1.45 mm) wire. Note the correct polarity indicated by the + sign on the AG case. Also, note that the DC power connector is removable with the DC wires attached.



Make sure your power supply can supply at least 300 mA @ 13.8 VDC. We strongly advise using a clean, high-quality DC power source for AG and all your other station equipment. Many cheap switch mode power supplies and “wall warts” are unstable and can generate surprising amounts of RFI well into the VHF spectrum.

8.5. Network cabling

Most home networks (LAN) operate at Ethernet (10 Mb/s), Fast Ethernet (100 Mb/s) or Gigabit Ethernet (1000 Mb/s) speeds. All of these networks work fine over Category 5 UTP or better rated cable such as Cat5e, which is widely available, or Cat6. Its likely the cable you are already using for your home network will work great with AG.

If you are unfamiliar with or need a refresher on home networks, a good primer from PC World is online here:

http://www.pcworld.com/article/196049/the_ultimate_guide_to_home_networking.html

100BASE-T networking has 328 foot (100 m) limitation between active devices (such as Ethernet switches). Keep this in mind when locating your AG.

Use a Cat5e, Cat6 or Cat6a UTP cable (not supplied, please don't use a cheap cable here; poor quality high speed data cables are never a good idea!) between the Ethernet port on your AG and your station LAN switch or hub (switches preferred over hubs). This should be the same place where your FLEX-6000 Signature Series radio connects to your LAN. Note this LAN connection can be as simple as a port on a DSL router or as fancy as as standalone Gigabit switch.

AG can be controlled by PCs connected over WiFi to your LAN as long as AG itself is connected directly to your LAN via a wired connection to an Ethernet switch or hub (switch recommended, Ethernet hubs will slow down your LAN). Here is the 24 port network switch and DSL modem @ W0LFA:



8.6. DIP Switch configurations

DIP 1 and DIP 2 set PORT A (which will typically be connected to Flex ANT1 or Radio A in non-Flex installations):

DIP 1	DIP 2	CONTROL
OFF	OFF	LAN control - FlexRadio
OFF	ON	BCD control
ON	OFF	Pin-to-Port control
ON	ON	Interface Genius control

DIP 3 and DIP 4 set PORT B (which will typically be connected to Flex ANT2 or Radio B in non-Flex installations)

DIP 3	DIP 4	CONTROL
OFF	OFF	LAN control - FlexRadio
OFF	ON	BCD control
ON	OFF	Pin-to-Port control
ON	ON	Interface Genius control

If you have more than one AG in your network, you should use DIP 5, DIP 6 and DIP 7 to assign a unique ID to each AG. You can have up to eight AGs in your system, with IDs from 0 to 7:

DIP 5	DIP 6	DIP 7	NETWORK ID
OFF	OFF	OFF	ID = 0
ON	OFF	OFF	ID = 1
OFF	ON	OFF	ID = 2
ON	ON	OFF	ID = 3
OFF	OFF	ON	ID = 4
ON	OFF	ON	ID = 5
OFF	ON	ON	ID = 6
ON	ON	ON	ID = 7

EXPERT TIP! You can have up to eight AGs on your station network, however, each AG **must** have a unique network ID from 0 through 7. The Network ID does not matter on single AG systems. Stations using more than one AG **must** use DHCP addressing to insure that each AG has a unique network address.

DIP 8 is used to reset your AG to factory presets **and sets the IP settings to DHCP**. If AG doesn't find a DHCP server on the network within ten seconds, the fallback address is 192.168.1.250. DIP 8 is also used when setting the AG network address on initial set-up for stations with network subnets other than the factory preset 192.168.1.xxx (see Section 9.2 below).

DIP 8	
ON	restore factory settings on next power cycle
OFF	normal operation

To reset AG to factory presets **including the 192.168.1.250 fallback address**, follow these steps in order:

1. disconnect AG from LAN
2. remove DC power from AG
3. move DIP 8 to ON position
4. turn DC power back on
5. move DIP 8 back to OFF position
6. reconnect LAN

The LAN needs to be disconnected during reset to keep AG from obtaining a network address from a DHCP server and overriding the factory preset address.

To reset AG to factory presets **but with a DHCP-assigned network address**, follow these steps in order:

1. leave AG connected to LAN (assumes there is a DHCP server on the LAN)
2. remove DC power from AG
3. move DIP 8 to ON position
4. turn DC power back on
5. move DIP 8 back to OFF position

DIP 8 must be set to ON when resetting the device and set to OFF in normal operation.

DIP 8 ON has no effect on the device in normal working mode without cycling DC power. After a successful configuration reset, make sure to set DIP 8 to OFF, otherwise you will reset your configuration on every power up!

8.7. LAN control

In this mode AG gets band data from FlexRadio SDR, using the TCP/IP network.

Switch off DIP 1 and DIP 2 to set PORT A to LAN control:

DIP 1	DIP 2	MODE
OFF	OFF	LAN control - FlexRadio

Switch off DIP 3 and DIP 4 to set PORT B to LAN control:

DIP 3	DIP 4	MODE
OFF	OFF	LAN control - FlexRadio

You can now connect your FlexRadio using the app. Click the configuration icon on top and choose Configure Radio(s):

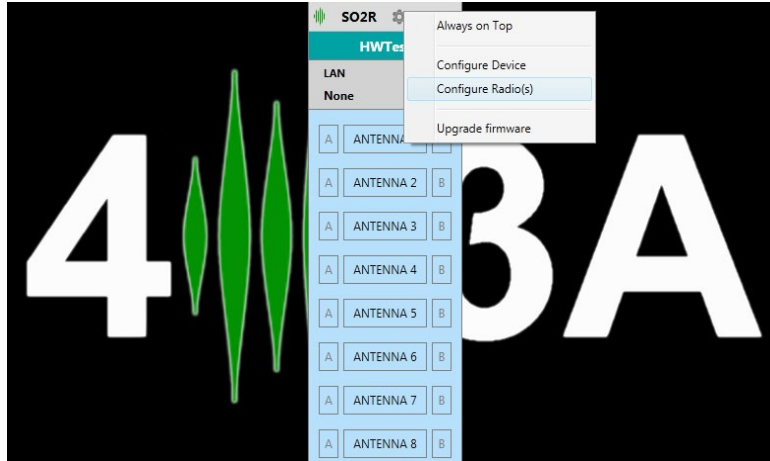

Your FlexRadio will be discovered automatically and listed on the right:

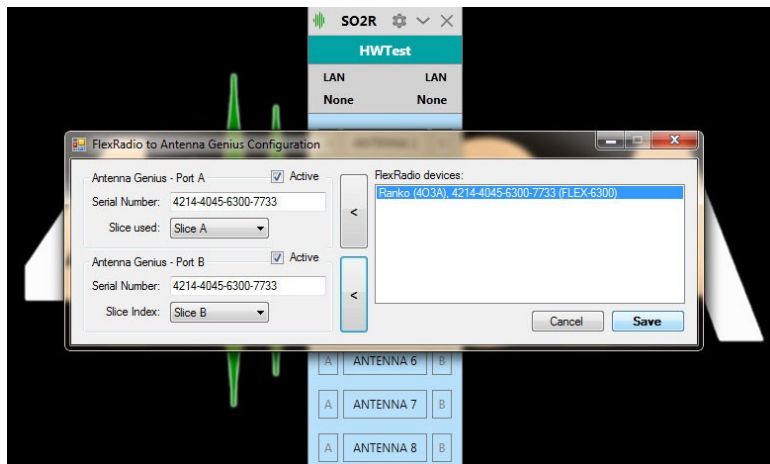

Click on a radio from the list and use the **arrow buttons** to assign the radio to Slice A and Slice B.

Set **Slice used** option to assign the desired slice to Port A and Port B, respectively.

Click Save and Reset.

8.8. Interface Genius control

In this mode AG gets band data from Interface Genius, using the TCP/IP network.

Interface Genius is our powerful SO2R interface and modem. More info on our website:
<http://www.4o3a.com/index.php/products/station-automation/interface-genius/>

Switch on DIP 1 and DIP 2 to set PORT A to IG control:

DIP 1	DIP 2	MODE
ON	ON	IG control

Switch on DIP 3 and DIP 4 to set PORT B to IG control:

DIP 3	DIP 4	MODE
ON	ON	IG control

You can now connect to the FlexRadio using the app. Click the configuration icon on the top and select Configure Device:

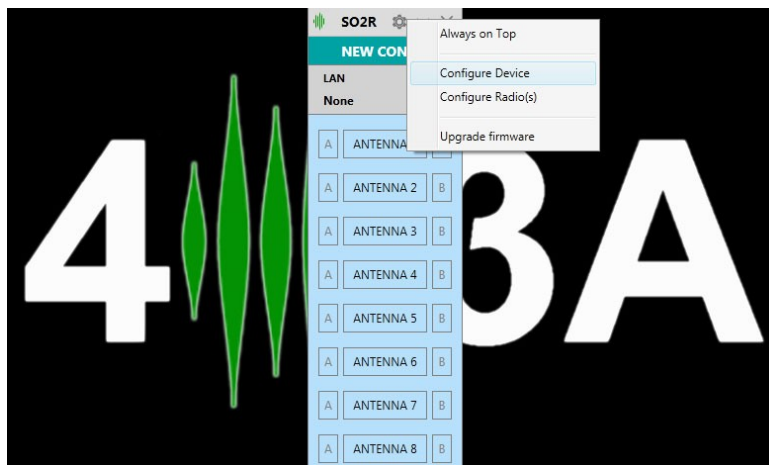

Enter the Interface Genius IP address for Slice A and Slice B and:

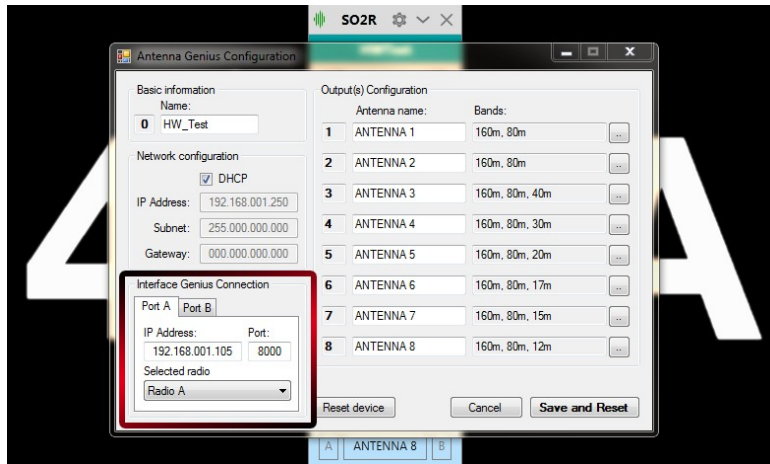

Leave the port at default 8000, unless you explicitly changed it on your IG.

Click Save and Reset.

8.9. BCD control

In this mode AG gets band data from radios using the standard BCD protocol.

Typical radios using BCD band data include Yaesu FT-1000 MP, FT DX 5000, FT-1000D, Elecraft K3, Ten-Tec Omni V and Orion II and many more.

Switch DIP 1 off and DIP 2 on to set PORT A to BCD control:

DIP 1	DIP 2	MODE
OFF	ON	BCD control

Switch DIP 3 off and DIP 4 on to set PORT B to BCD control:

DIP 3	DIP 4	MODE
OFF	ON	BCD control

This is the pinout when looking at the device connector:

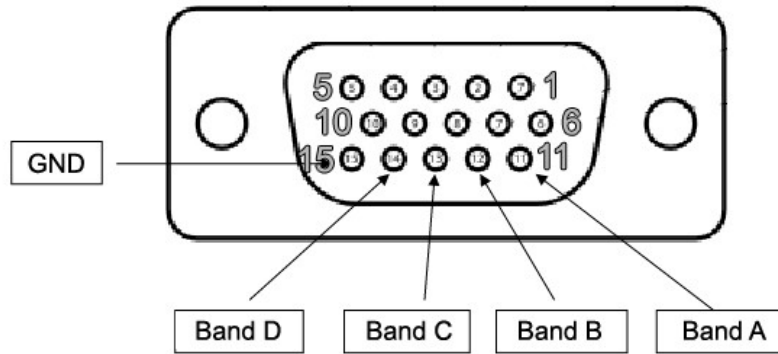

This is the BCD data table:

Band		160m	80m	40m	30m	20m	17m	15m	12m	10m	6m	None
Frequency		1.8	3.5	7	10	14	18	21	24	28	50	NA
Yaesu	Band A	H	L	H	L	H	L	H	L	H	L	L
	Band B	L	H	H	L	L	H	H	L	L	H	L
	Band C	L	L	L	H	H	H	H	L	L	L	L
	Band D	L	L	L	L	L	L	L	H	H	H	L
	HEX Code	1	2	3	4	5	6	7	8	9	A	0

8.10. Pin-to-Port control

In this mode you can use an external switch for manual switching.

Switch DIP 1 on and DIP 2 off to set PORT A to PTP control:

DIP 1	DIP 2	MODE
ON	OFF	BCD control

Switch DIP 3 on and DIP 4 off to set PORT B to PTP control:

DIP 3	DIP 4	MODE
ON	OFF	BCD control

This is the pinout when looking at the device connector:

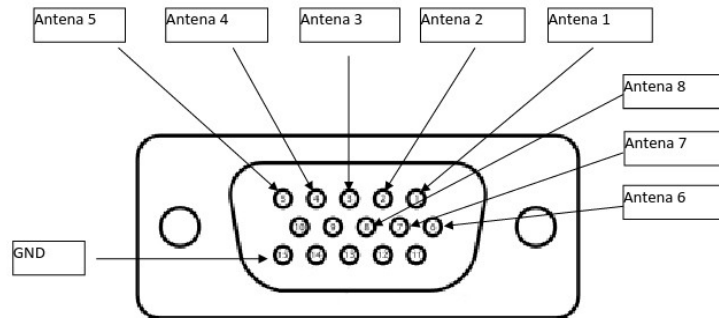

You can use the 4O3A manual controller for this purpose:

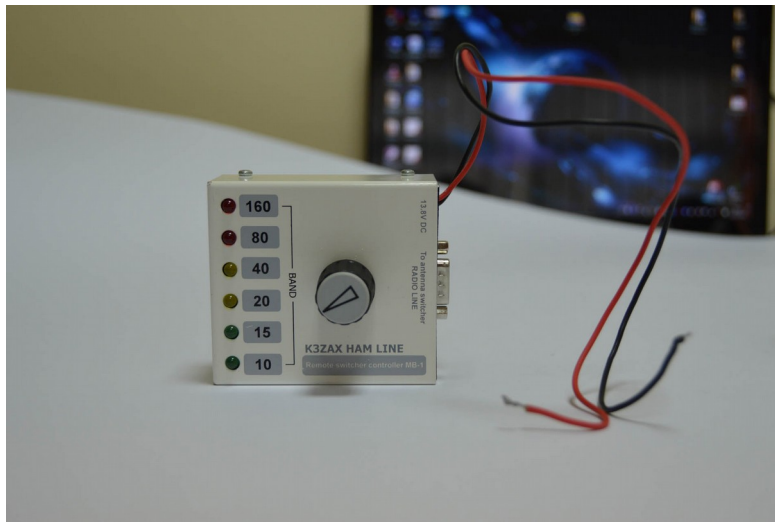

9. ANTENNA GENIUS™ APP

The AG App performs five tasks:

1. Programming band-antenna assignments for automated operation: antenna selection driven by radio band data received direct from SmartSDR, radio, via Interface Genius, or relayed through logging software; for Flex users this will typically be a SSSDR connection
2. Providing a Windows interface for manual antenna selection, an alternative to automated antenna selection
3. Secondary antenna selection when there is more than one antenna available for a band(s), AG will default to last antenna selected for a particular band in automatic mode after which operator can manually select an alternative antenna for that band. Note that you will be prohibited from switching to antennas which have not been programmed for the band in question (unless band is set to none and the antenna is band independent).
4. Interface for radios, logging programs, and other applications that don't communicate directly with AG

5. Updating AG with the latest firmware

EXPERT TIP! AG will default to last antenna selected for a particular band in automatic mode after which operator can manually select an alternative antenna for that band. Note that you will be prohibited from switching to antennas which have not been programmed for the band in question.

9.1. Initial set-up

9.1.1. Confirm DIP switches

First, make sure you've set the DIP switches to suit your installation (see Section 8.6 above) and you have connected DC power and the appropriate Port A and Port B control connections (LAN, BCD, or Pin-to-Port) to AG.

9.1.2. Download and install the AG Windows App

The AG Windows App has been tested to run on Windows 7, 8.1 and 10, both Pro and Home and both 32 and 64 bit editions, and is available free from the Downloads page on 4O3A.com:

<http://4o3a.com/index.php/downloads>

Antenna Genius



Download the AG Windows App to your PC's Downloads folder. You may see an error message from your browser or security software for trying to download a Windows executable file (.exe file), you may override this warning if you are confident you have downloaded the file from 4O3A.com.

First, select the installation language from the pull-down menu and select **OK**.



After closing all other applications, launch the Setup Wizard by selecting **Next**:



Fill in your User Information (Organization field is optional) and hit **Next**:

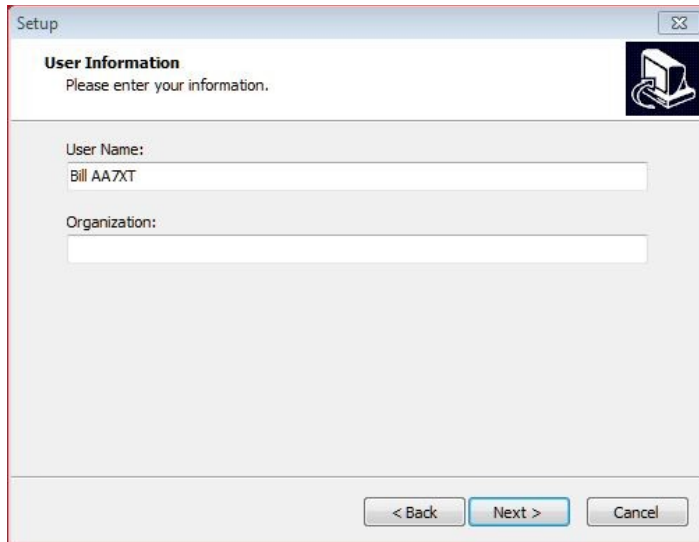

Select Destination Location, we recommend you keep the default location:

C:\Program Files (x86)\4O3A Signature\Antenna Genius

and hit **Next**:

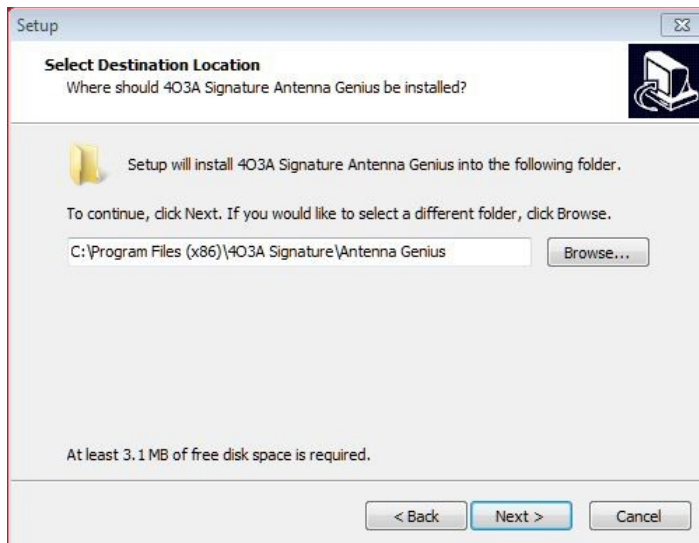

If you want a AG App desktop icon, leave “Create a desktop icon” selected and hit **Next**; otherwise, deselect “Create a desktop icon” and hit **Next**:

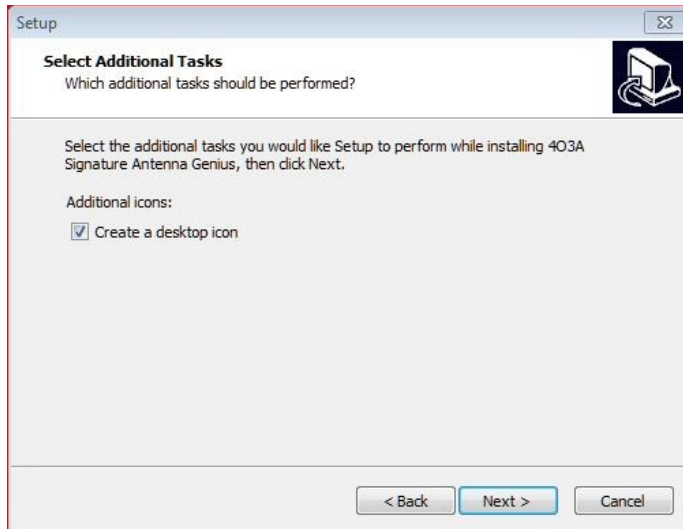

Now you should see the Ready to Install window. Double check the data, if correct, hit **Install**. If not correct, use the Back button to navigate to the applicable window and revise

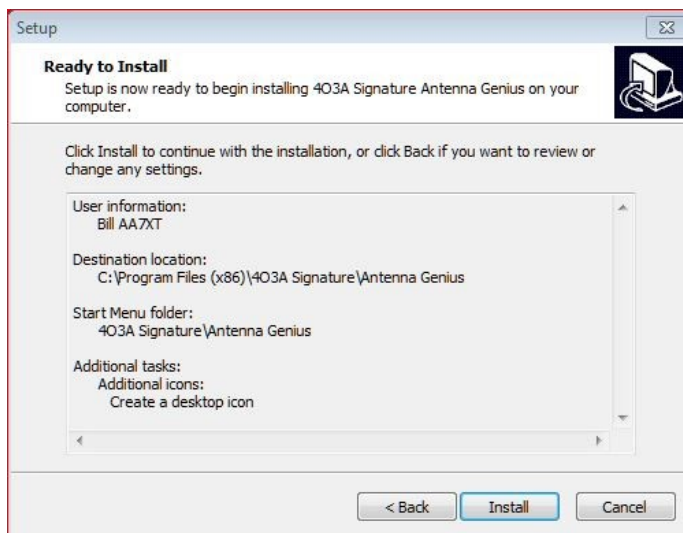

Hit **Finish** to launch Antenna Genius Windows App:



9.1.3. Using DHCP to set the network address

AG comes factory preset for DHCP. If there's no DHCP server the fallback address is 192.168.1.250.

It is recommended to use your network's DHCP server (Dynamic Host Configuration Protocol), which is built into an Ethernet switch or DSL router on most home networks.

In case you are having problems getting an IP address, you can try resetting the configuration on your AG:

1. make sure AG is connected to LAN with a DHCP server that will assign an IP address (in home networks, typically an Ethernet switch or DSL router)
2. remove DC power from AG
3. move DIP 8 to ON position
4. turn DC power on
5. move DIP 8 back to OFF position

Note this will reset the entire configuration on the device, including antennas, IP configuration etc.

If AG does not find a DHCP server on the LAN it is connected to, it will fallback to these network factory settings:

IP address	192.168.1.250
net mask	255.255.255.0
subnet	192.168.1.0
port:	9007

See Section 9.2 below for information on setting up a static IP address.

**On [TCP/IP](#) networks, subnets are defined as all devices whose [IP addresses](#) have the same prefix. For example, all devices with IP addresses that start with 100.100.100. would be part of the same subnet with 256 network addresses available from 100.100.100.0 to 100.100.100.256*

Take a look at the green and yellow LEDs on your AG LAN port. A lit green LED indicates network connection and a flashing yellow LED indicates network 'traffic.' It is normal for the yellow LED to flash even if you are not actively sending band change data to AG.

EXPERT TIP! The terms “LAN,” “home network,” and “network” are used interchangeably in this document, both referring to the small TCP/IP-based Ethernet networks many hams will have in their homes and shacks. “TCP/IP” is the basic set of protocols that runs the Internet and also powers most modern home networks. The router built into DSL or cable modems demarcates and routes data between the “Local Area Network” (LAN) in the home from the “Wide Area Network” (WAN) on the side, usually the Internet.

9.1.4. Setting the network address manually

Select Configure Device in the AG Windows App Gear icon menu, uncheck DHCP, and enter your preferred network IP Address, Subnet and Gateway.

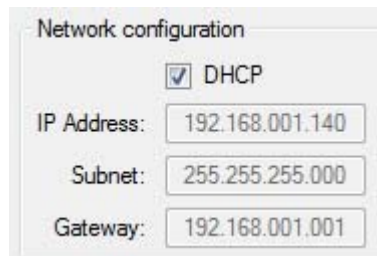

Network configuration

DHCP

IP Address: 192.168.001.140

Subnet: 255.255.255.000

Gateway: 192.168.001.001

9.1.5. Launch the Windows App

When you first run the AG Windows App, it will open the AG Launch window:

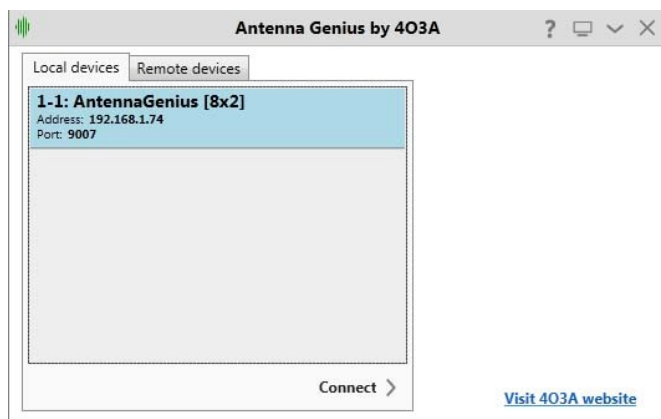

Your AG should be detected automatically by the app. If so, simply click on Connect.

If you don't see your AG under Registered devices, it is possible your LAN subnet does not correspond with your AG device network settings. Try resetting the device IP address via DHCP.

9.1.7. Programming antenna data

Select the applicable AG in the Registered devices list (you can have up to eight AGs on your network) and select **Connect**. You should see the AG Control window (Both - SO2R mode pictured):



EXPERT TIP! You can select “Always on top” the AG App in Windows to make it easy to find and launch. Just click on configure and select **Always on Top**

9.2. Device Information

Click on the gear icon and select “Device Information”.

The Device Information selection in the Windows App Gear menu has comprehensive info on your Antenna Genius and its settings. You cannot change any settings in this window, it is for displaying device status only.

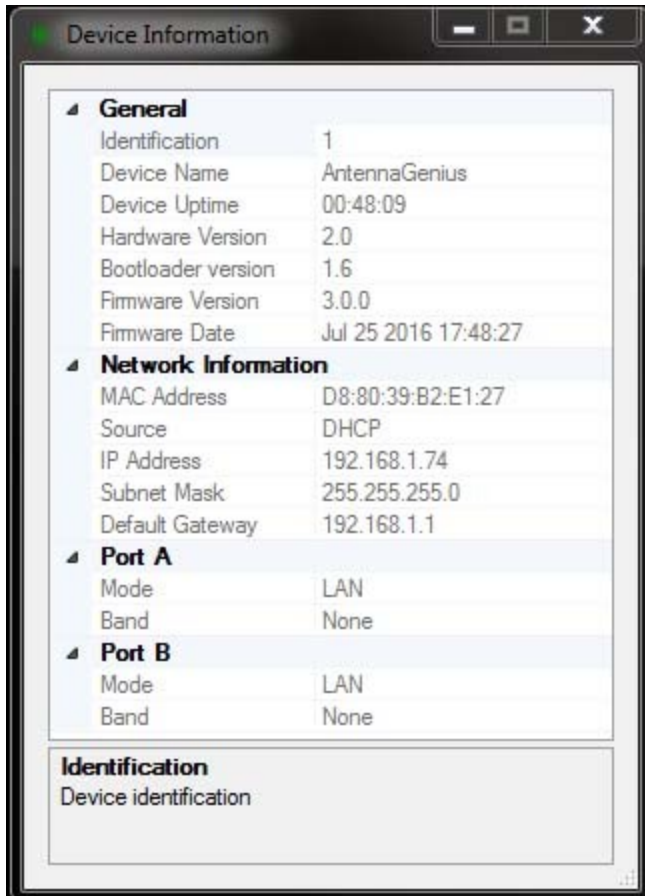

Identification	Device identification number between 0 - 3 set by DIP switches, if you only have one AG this can be any number; if you have multiple AGs on a single LAN, each number must be unique and you can have up to eight AGs on a one LAN
Device Name	Up to sixteen user selected alphanumeric characters
Device Uptime	Time since last device power cycle or reboot
Hardware Version	Self-explanatory

Firmware Version	AG firmware is upgradable so that new features can be added over time, see section 9.3 below for instructions on updating your AG firmware
Firmware Date	Date that corresponds to your AG's firmware revision
MAC Address	Media Access Control Address, also known as the physical address, a unique identifier assigned by the manufacturer to network interfaces, cannot be changed by user
Source	IP address assignment method: DHCP or manual
IP Address	Internet Protocol Address, a numerical label assigned to each device participating in a computer network that uses the Internet Protocol for communication, AG uses IPv4 addresses set by DHCP or manually
Subnet Mask	Set by DHCP or manually, usually 255.255.255.0
Default Gateway	The LAN address of the router, set either by DHCP or manually
Port A Mode	Control method for Radio Port A as set by DIP switches, either LAN, IG, BCD or PTP.
Port A Band	Current band detected for Port A Radio
Port B Mode	Control method for Radio Port A as set by DIP switches, either LAN, IG, BCD or PTP.
Port B Band	Current band detected for Port B Radio

9.3. Is your firmware up-to-date?

If the firmware on your AG is older than the latest AG firmware, you should update your AG before proceeding to the rest of the setup sets.

The firmware version should always match the app version.

Since 3.03 the firmware file is included into the app. There is no need to download a separate file anymore.

Before updating the firmware you should make sure you have the latest version of the AG Windows app by checking the 4O3A.com Downloads page (see below). Updating the app is simple, just download and install using the same procedure as in an Initial Set-up described in 9.1 above. Don't worry, your current app user data will *not* be overwritten.

Connect to your AG using the new app. A message will appear to let you know you need to upgrade the firmware.

It will also attempt to reconnect, this is normal behavior.

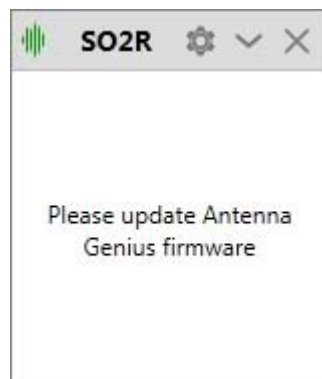

Click on the configure icon, and select load firmware. The corresponding firmware file will be preloaded. Click upgrade and wait for the process to finish.

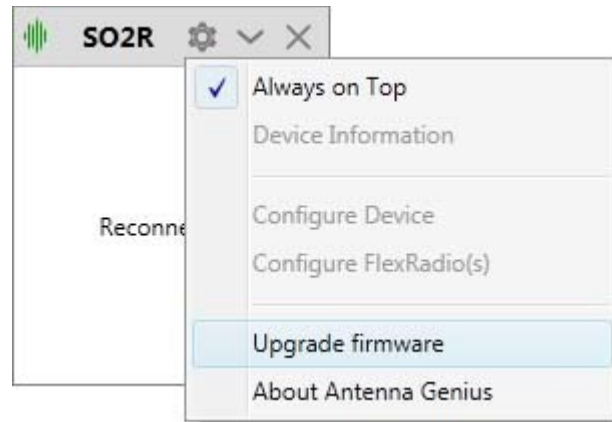

Make sure you are using a wired network connection between your computer and AG while upgrading. If you are using a wireless network you run the risk of bricking the device.

The green progress bar will fill from left to right.

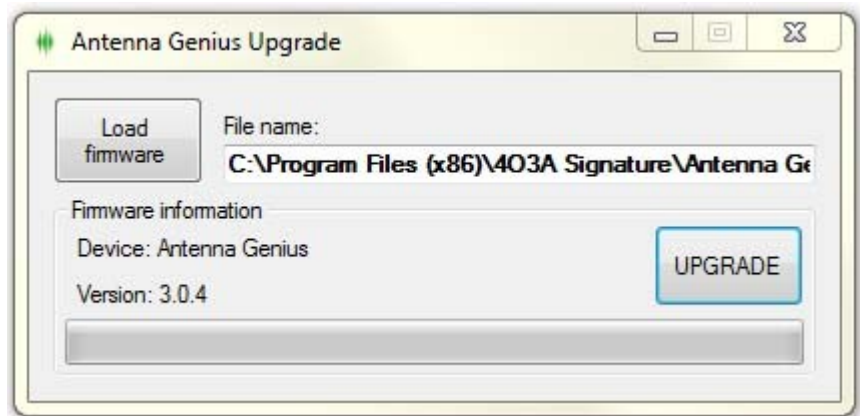

When the update is complete, you will see an Updating completed notice. Select OK.

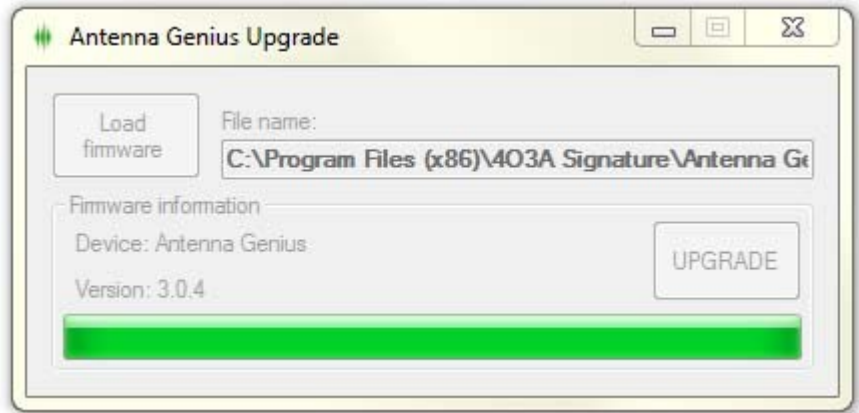

When the update is complete, you will see an Updating completed notice. Select OK.

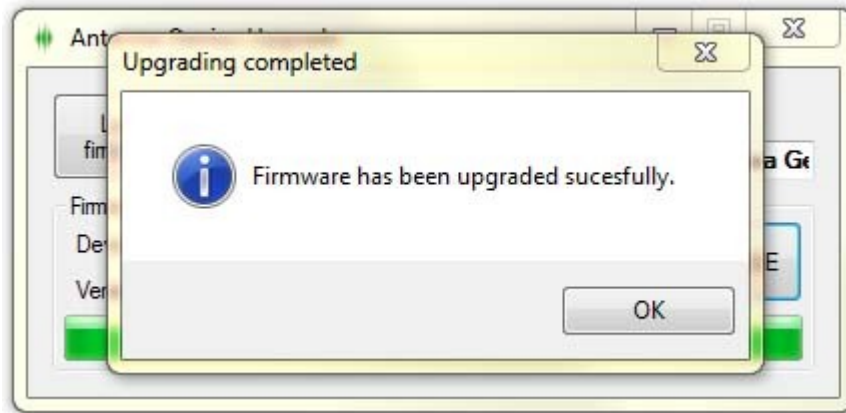

Your AG is now up-to-date!

9.4. AG Control Window programming

If you have selected Port A or Port B mode, your AG Control Window prior to initial antenna programming will look like this, in this example both Radio Port A and Radio Port B are using LAN mode:



We will connect to a FlexRadio in this example. Select "Configure from the Gear icon menu.

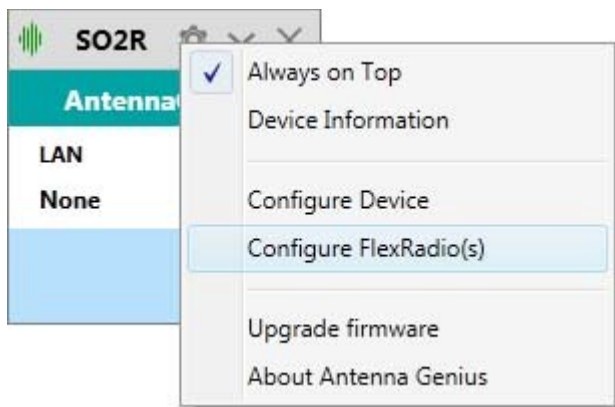

Since 3.0.3 you don't bind to slices, but to antenna ports instead. This allows you to utilize the slice concept to the maximum.

All the FLEX-6000 Signature Series radios on your LAN should appear under FlexRadio devices. If you have a single FLEX-6000 Signature Series radio on your network, as most users will, it's simple: select it and then select the < button for both Port A and Port B and then tick the Active box for both ports. The Serial Number reported here is from your radio.

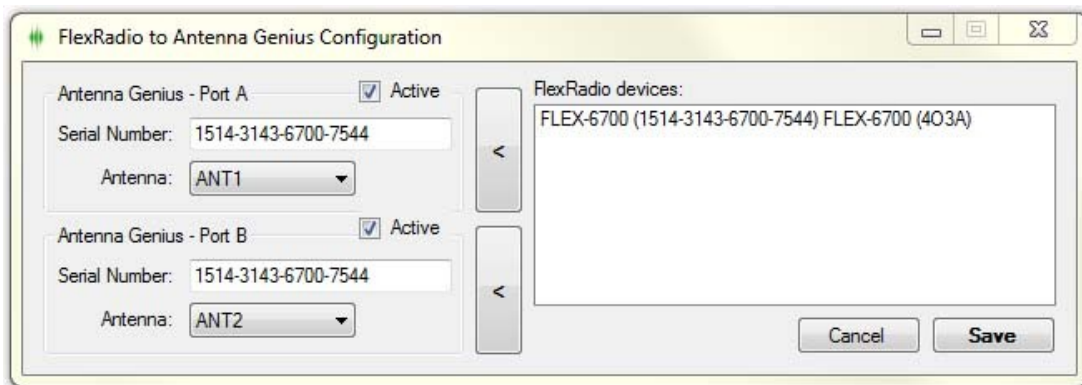

If you have more than one FLEX-6000 Signature Series radio on your network, select the appropriate radio to link to this AG.

Click save and lets see the Antenna Genius settings:

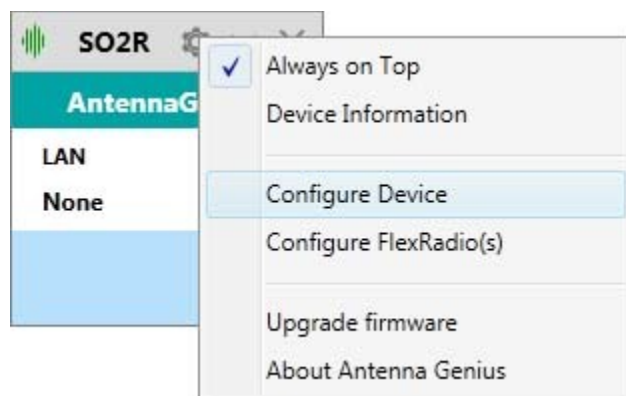

Ignore the Interface Genius Connection info, its not relevant for most FLEX-6000 Signature Series users. The Network configuration can also be ignored in this step if you are running in the default DHCP mode. See Section 9.1.4. for information on manually setting the AG network address.

EXPERT TIP! “network address” and “IP address” refer to the same thing and are used interchangeably in this document

Now it's time to program your antenna-band assignments. Select Configure Device from the Gear icon menu:

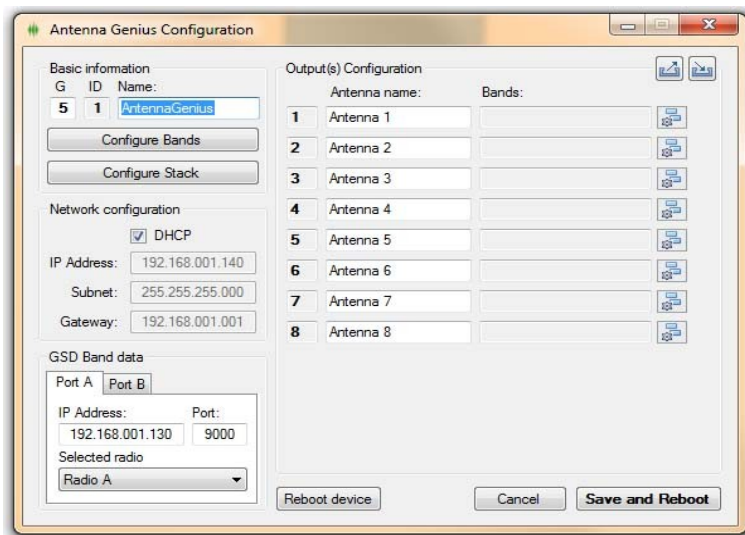

Fill in your antenna info giving each antenna a unique name up to ten alphanumeric characters long including spaces. For each antenna, select the applicable band or bands that are usable with that particular antenna. You can have multiple antenna options for a particular band; for example, in the set-up below “Multi V” is a wideband vertical usable on 20 through 10 meters and can therefore be selected by clicking on the A or B buttons if not first automatically selected by AG. When there are more than one antennas available for a particular band, AG will return to the last antenna used for that band when that band is selected.

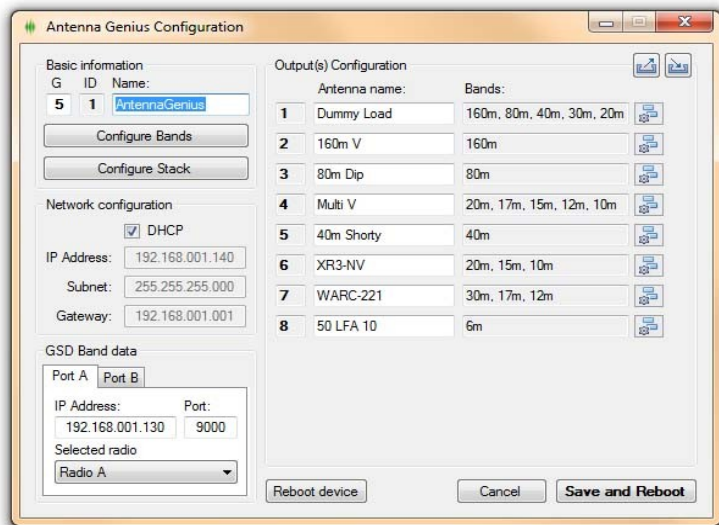

The 'None' option in the Band selector allows selection of an antenna for use outside of the ham bands, for example, a long wire to be used to listen to WWV or shortwave broadcast stations.

After you're done programming your antenna and band connections, select Save and Reset, AG App will write your antenna-band logic to your AG. The Reset device button re-sends the current antenna-band data to AG.

EXPERT NOTE! There are plans to add three user-definable bands to the Band selection list in a future software and firmware release. This would allow new and future amateur radio bands such as 137.2 and 472 kHz to be supported and also to accommodate users authorized to operate outside the amateur bands such as MARS and CFARS licensees.

9.4.1. Full duplex 'in band' operation

This feature is still not implemented and will be released as a software update!

AG's high port-to-port isolation figures, in addition to powering high-performance multi-radio contest operation (SO2R including Flex-SO2R, multi-single, and multi-two) on two separate bands, enables single radio 'in band' full duplex operation with the FlexRadio.

EXPERT NOTE! AG's built-in hardware (relay interlocking for each antenna port) and firmware protection prevents both radio ports from being connected to the same antenna at the same time. Note, however, that this does not prevent you from putting, for example, Slice A / ANT 1 / Port A to a 20m Yagi and Slice B / ANT 2 / Port B to a multiband vertical antenna with both Slices tuned to 20m. FLEX-6700 transceivers can operate in full-duplex mode so users should exercise caution when listening 'in band' (transmitting and receiving simultaneously on the same amateur radio band). AG's built-in protection does not protect your radio from overload damage in full duplex mode with tx and rx frequencies and antennas in close proximity.

10. OPERATION

10.1. Local (LAN) operation

After programming your AG antenna-to-band associations, you are ready to go! If SmartSDR is not running your Control window will look like this with no antennas selected for either port:

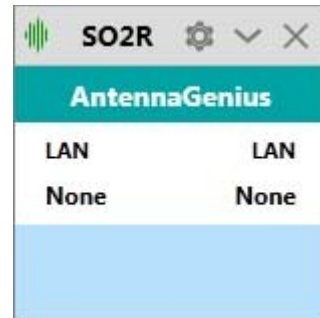

Launch SmartSDR and AG should read the current Slice band data, here is an example:

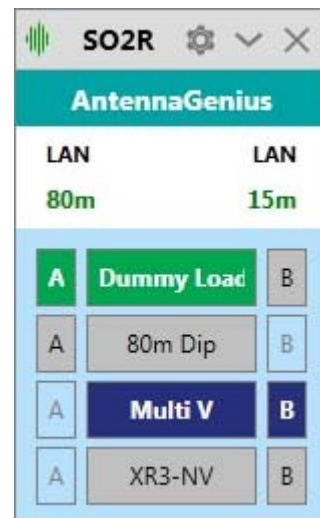

In the example above, Slice A is connected to AG Port A and Slice B is connected to Port B. Slice A is on 20m thus AG identifies the three antennas that have been assigned to 20m: the currently selected antenna, a Delta 6BA, by filling the Delta 6BA **A** box in green. The two other 20m antenna options, a multi-band Flagpole antenna and a Magnum 620 monoband Yagi, are indicated by grey **A** boxes. You can move between the 20m antenna options by selecting the applicable **A** box. You cannot select antennas which have not been activated for the band in question. You also cannot select the antenna being used on the other port even if it is activated for the band you are using, this protects your radio from possible front end damage.

10.2. Internet (WAN) remote operation

You can currently use AG over WAN by using a VPN (Virtual Private Network). Google "VPN" if you want more info on this topic.

Expanded support of WAN operation is planned for future AG firmware and software updates.

11. ADDITIONAL FEATURES

11.1 Stacking multiple AG's into a superswitch

You can now combine multiple 8x2 Plus units for 16x2, 24x2, and even 32x2 switching capability. Implemented with a **Master / Slave** design. Master unit does all the logic and slave units one obey its commands.

In the simplest scenario configuration we use two AG 8x2 Plus units and two 4O3A AB Switches to create 16x2 switch.

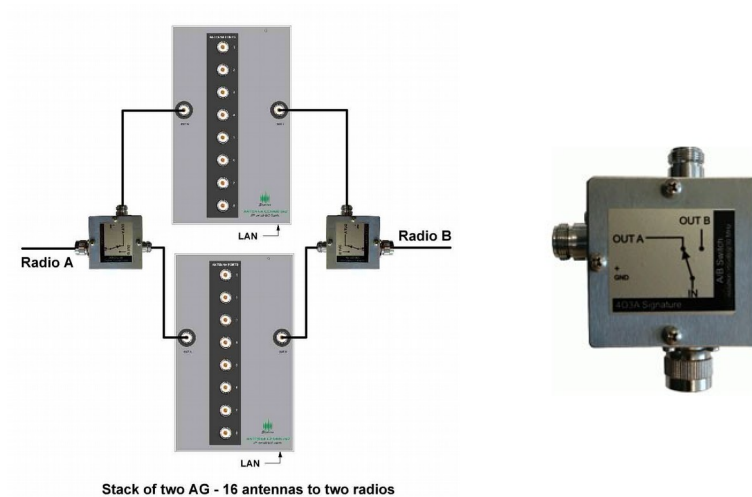

First we need to configure the top device as a **Master** device. It is the one taking over control and the one we will be connecting to. It hosts the main configuration file.

There is only one configuration file for a stack configuration.

The bottom device will be configured as a **Slave** device. It will be standing by for commands.

Keep the bottom device powered off to make sure you're connected to the right one.

Connect to the top device, click the Gear icon and select **Configure Device**.

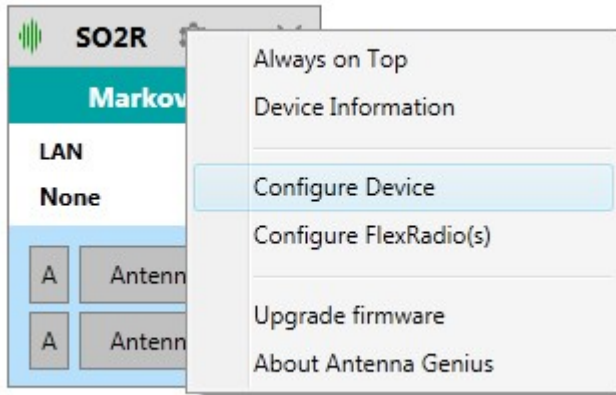

Notice the G and ID numbers in the top left corner. We will set Group as 1 and ID as 1 for this unit.

You can change the Group ID by editing it directly in the app.

You change the ID by setting DIP switches on the device. To set ID as 1, set DIP 5, DIP 6 and DIP7 to **OFF**.

Click the **Configure Stack** button in the upper right corner:

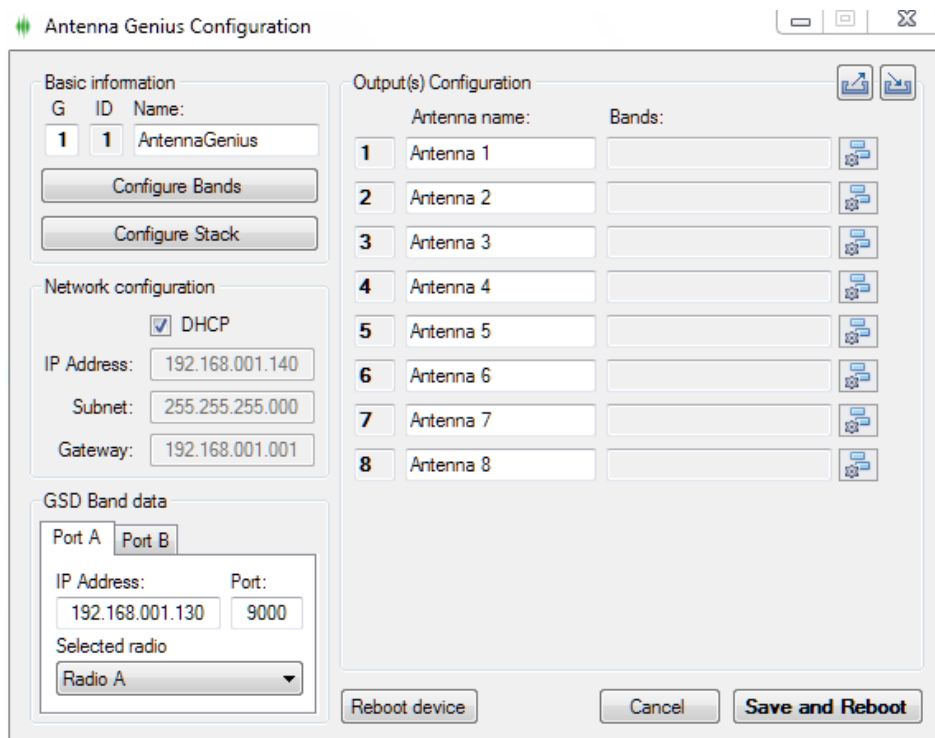

Set Mode to Master, and Length to 2 (total number of AG's in the stack). Click **Accept**, then **Save and Reboot**.

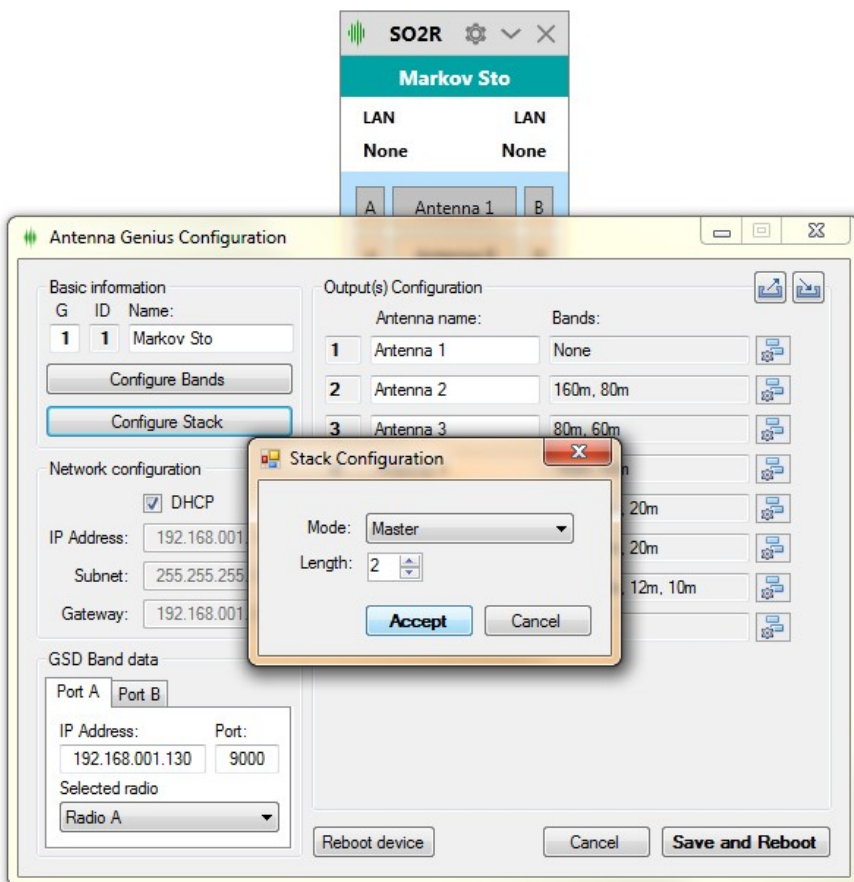

The device will reboot and reconnect. When you back to the configuration menu, you will see 16 antenna entries.

You will configure it in the exact same way as the 8x2 switch, but first lets configure the Slave device.

Disconnect from the Master unit. Power it off.

Power on the Slave unit. Connect to it.

Configure the mode to Slave.

Set the Group as 1 by editing it directly from the app.

Change the ID by setting DIP 5 to **ON**, DIP 6 and DIP7 to **OFF**. Press **Accept**, then **Save and Reboot**.

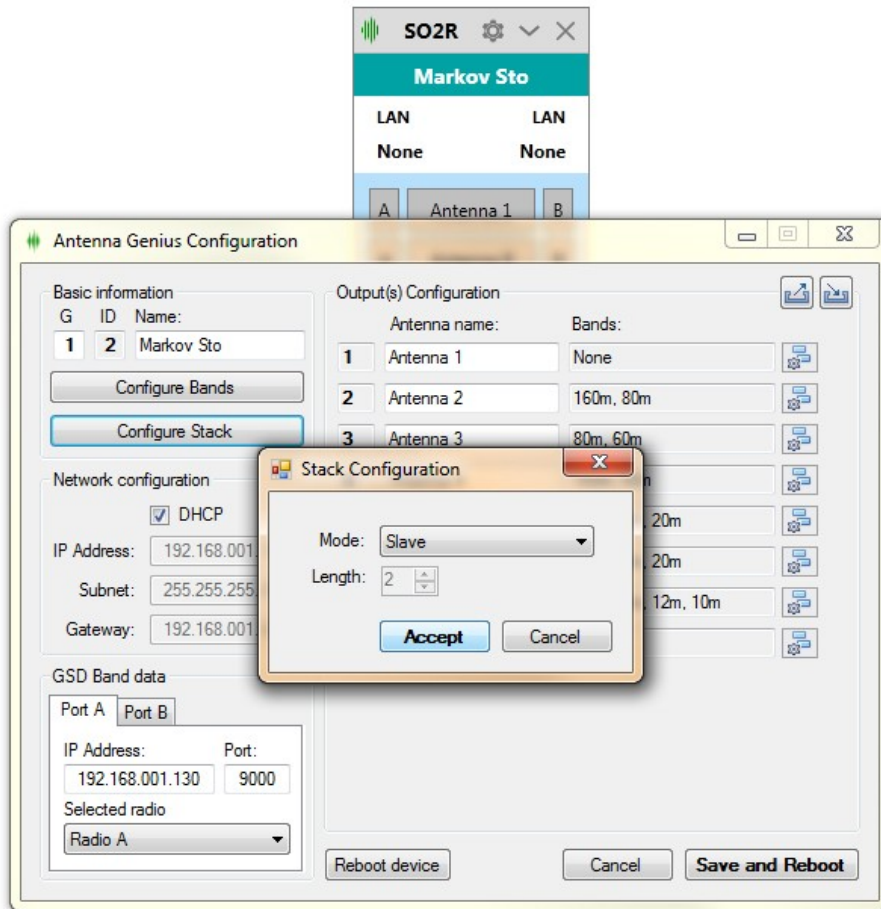

Power on both of the devices, connect to the first AG.

Configure your antennas and enjoy your new super switch.

11.2 Custom Band Configuration

In the configuration window, click the **Configure Bands** button.

Antenna Genius Configuration

Basic information

G	ID	Name:
1	1	AntennaGenius

Configure Bands

Configure Stack

Network configuration

DHCP

IP Address: 192.168.001.140

Subnet: 255.255.255.000

Gateway: 192.168.001.001

GSD Band data

Port A Port B

IP Address: 192.168.001.130 Port: 9000

Selected radio

Radio A

Output(s) Configuration

	Antenna name:	Bands:
1	160m Vert	None
2	80m 8 Circ	80m
3	Magnum 340	40m
4	Magnum 620	20m
5	XR3 NV +	20m, 15m, 10m
6	WARC 22	17m, 12m
7	6 LFA 10	6m
8	FPA OCF	80m, 40m, 30m, 20m, 17m,

Reboot device Cancel **Save and Reboot**

We have received many requests to allow users to define bands, and we added in a couple of extra user-defined bands as well:

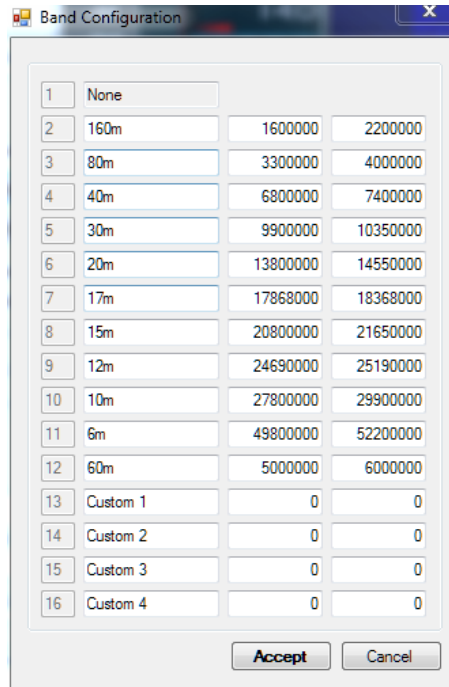

You can now manually tweak and adjust any band frequency range. Four new custom bands reserved for non standard bands.

These settings are saved in the main configuration file. Press **Accept**, then **Save and Reboot** to apply changes.

11.3 Output Module Relay Control

You can now control our OM modules, originally designed for Station Genius. Added for controlling 4 Square antenna arrays.

11.3.1 Output Module Hardware

Outputs A and Outputs B are different contact of DPDT relays. Each port can be used **differently** to supply internal 12V (not recommended), any external voltage, or GND.

In other words:

- Every logical output (Outputs labeled 1,2,3... in software/on the sticker) has two physical outputs (blue screw terminals).
- This is to enable switching of two separate independent devices.
- These two physical outputs can be configured differently.
- Either one of them can be set to internal +12V, external voltage or GND.

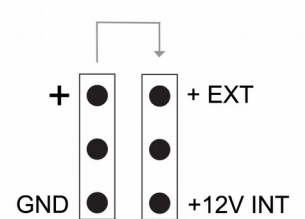

If you select GND the jumper EXT/INT jumper position doesn't matter.

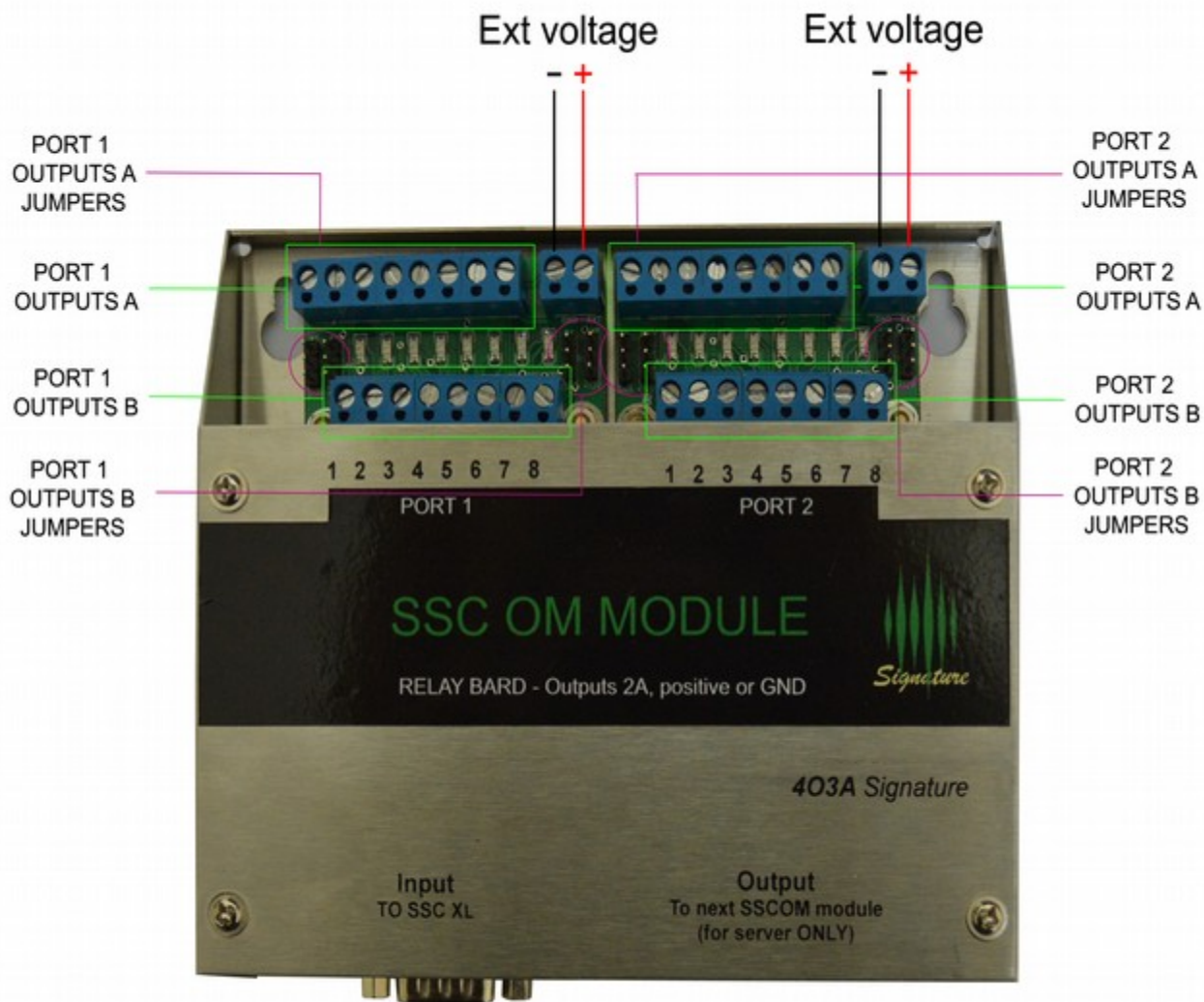

Internal voltage is used for testing and programming, and it is strongly recommended to use proper external power supply and set jumpers to EXT. Internal power supply in AG is 1A, which is on the margin if all relays are in use.

11.3.2 Output Module Connection

Connect your OM module to the OM module connector. Use a straight 9 pin RS232 cable.



Below is a picture of how it looks connected together:

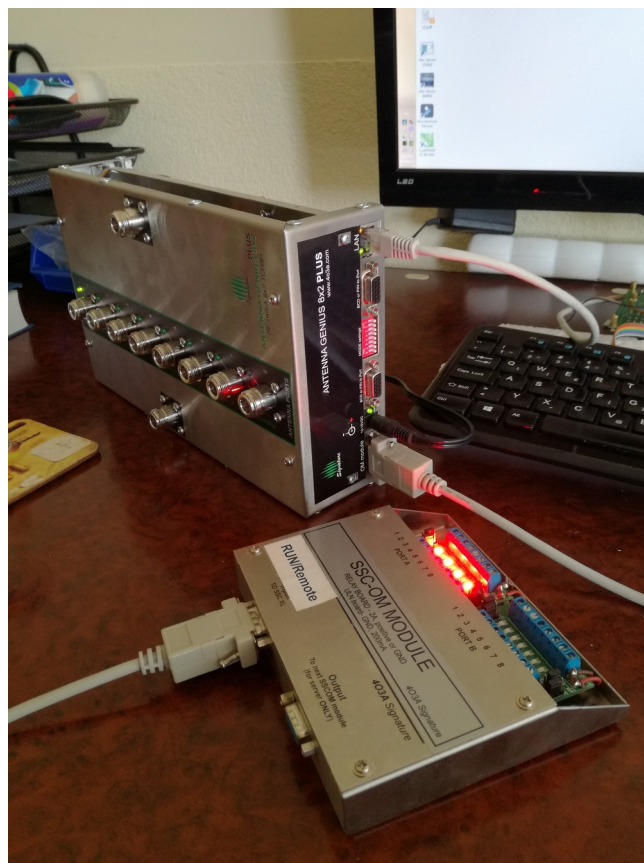

11.3.3 Software configuration

Click on the OM configuration button next to one of the antennas.

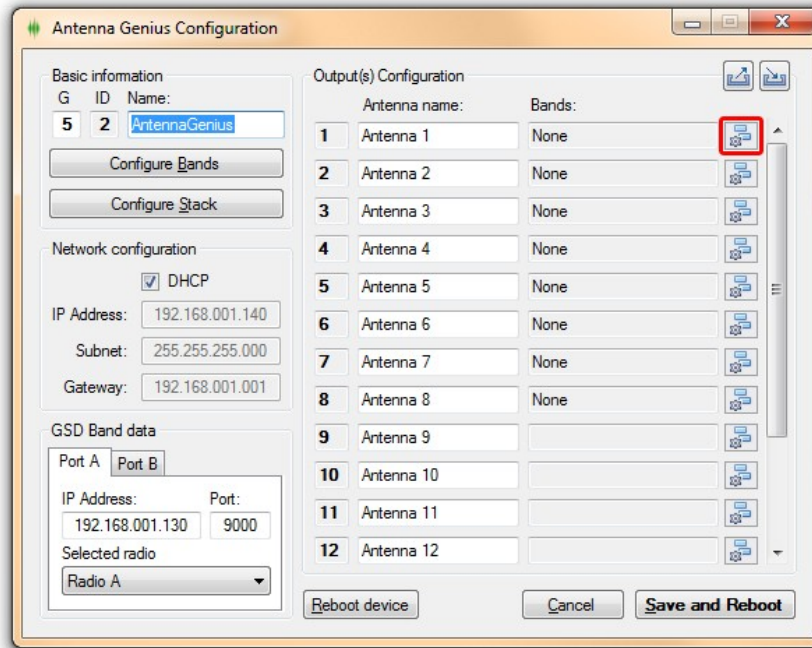

You will enter a new menu. You can use the + button (top right corner) to add buttons, and x to remove buttons (right most button in the antenna entry). You can name your OM entries by typing them into the textbox.

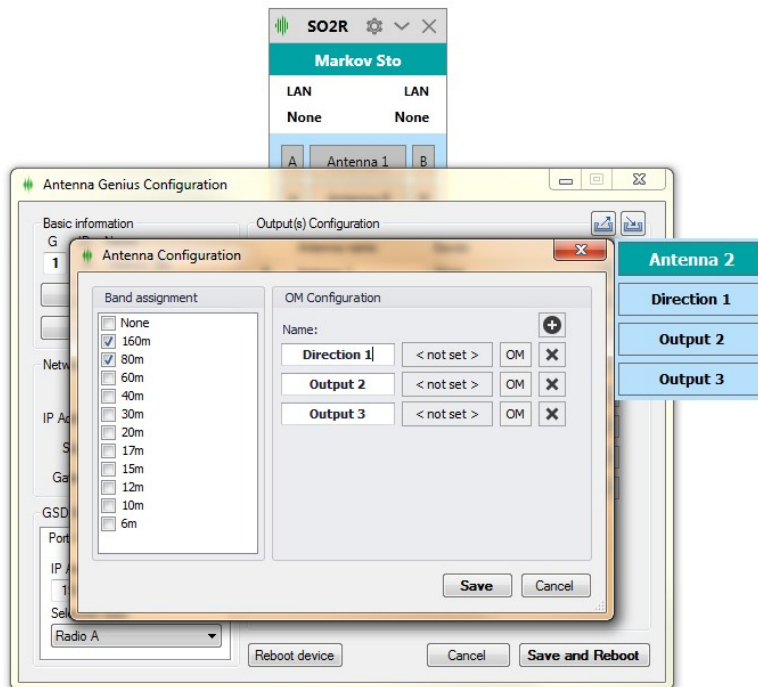

The < not set > field to the right is for the keyboard shortcut. Click to set. Set it to Alt + 1 for example. Press Enter to confirm.

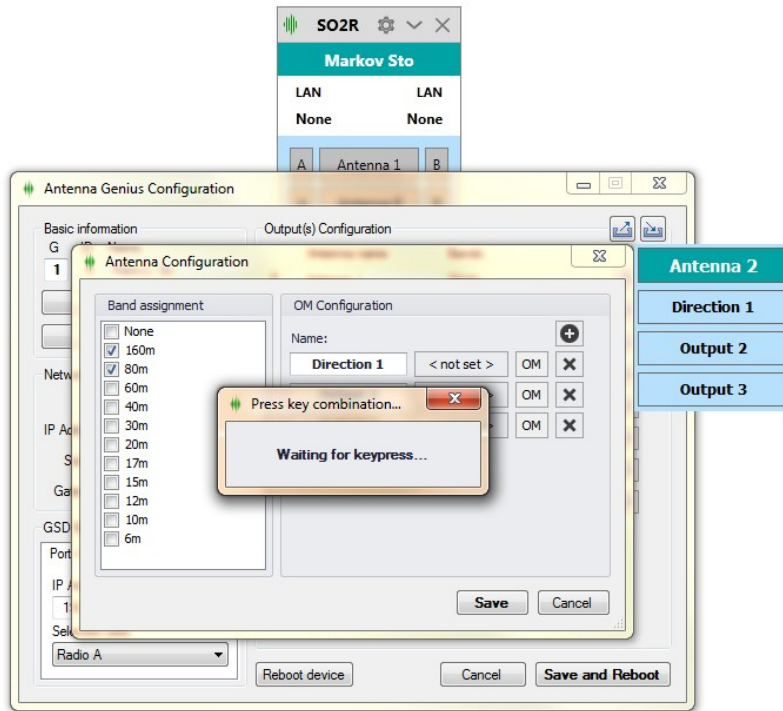

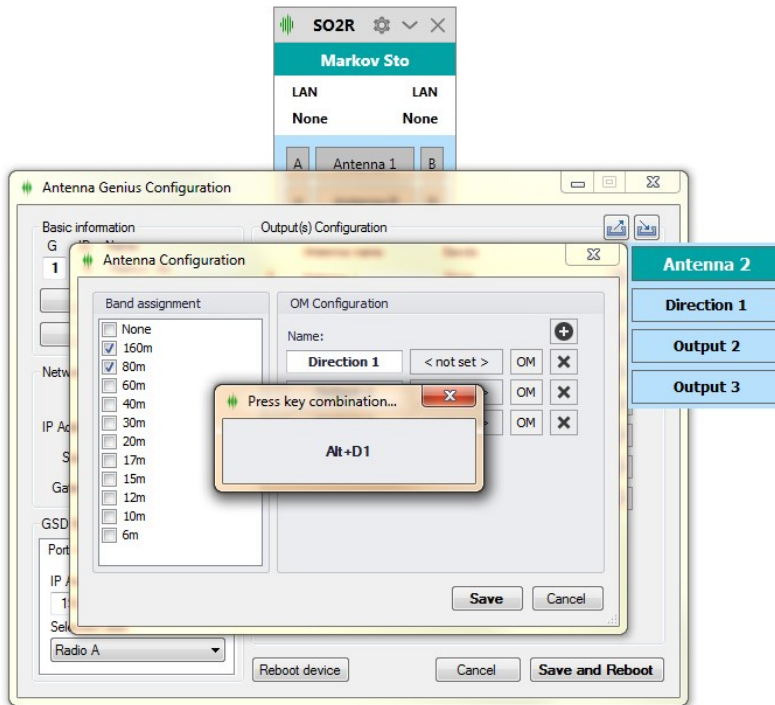

Click the OM button to set the relays you wish to control. You toggle states by clicking on the output icon. There are three possible states:

3	Not used by the button.
1	Turn off this output.
9	Turn on this output.

Click **Accept** when done.

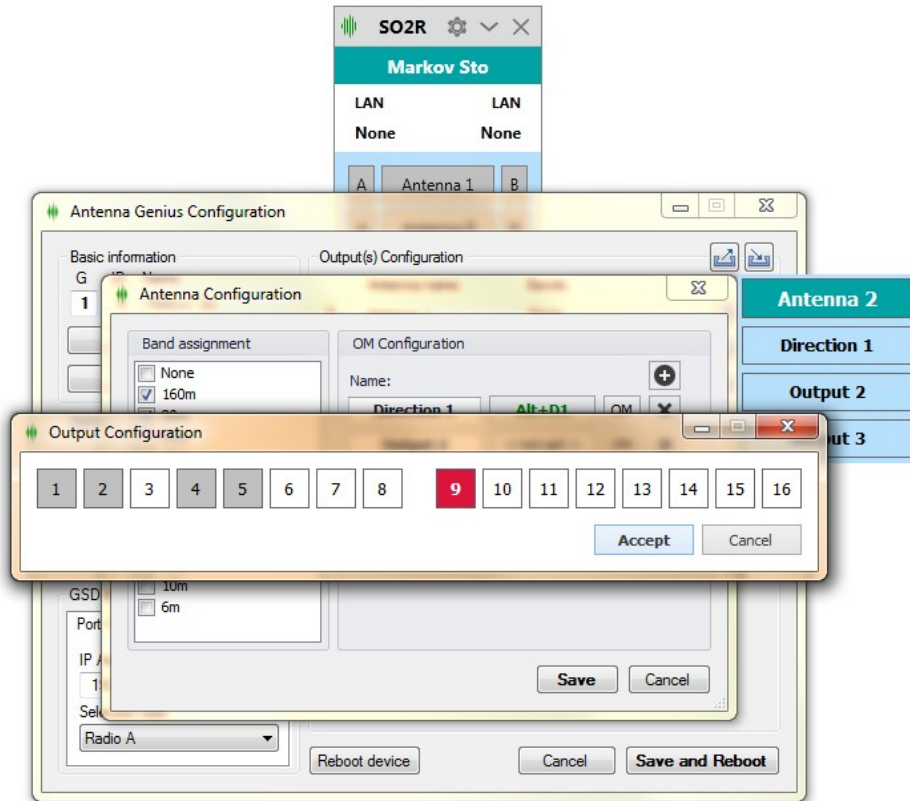

Repeat the process. It should look something like this in the end.

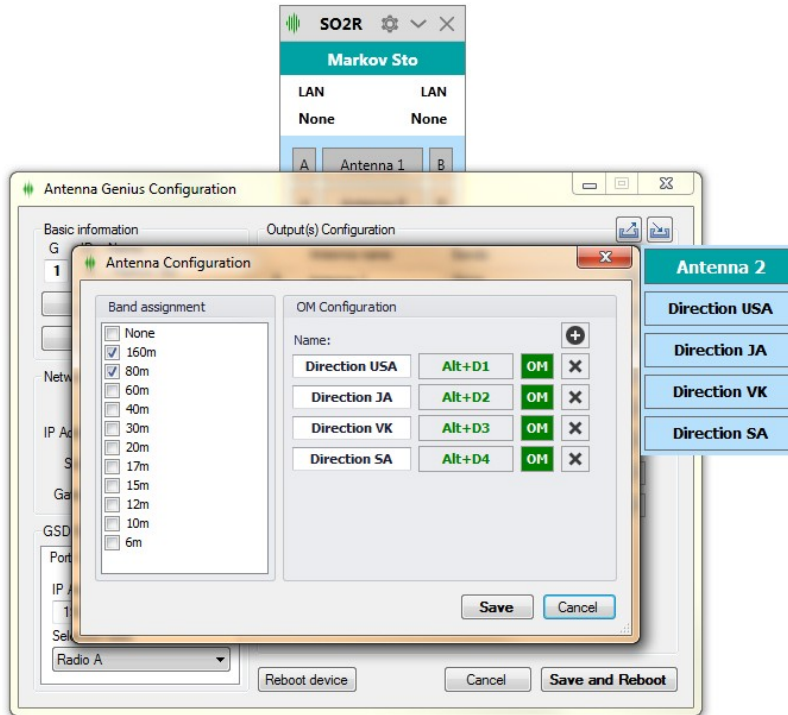

Press **Save**, then **Save and Reboot**. Next time this antenna is selected, a window will appear as well.

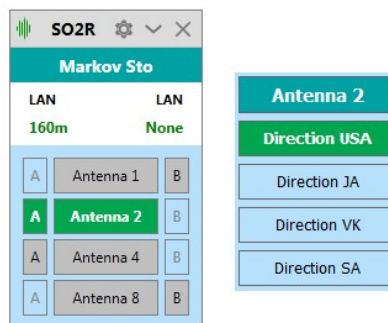

11.4 PTT sense

When not using PTP mode, you can wire your PTT signal to PIN1 on the BCD/PTP connector. The signal needs to be +12V.

AG will not switch antennas while this signal is being received.

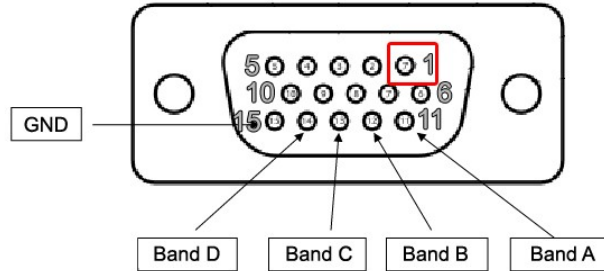

11.5 Auto connect on startup

You can configure your AG shortcut to skip the discovery screen and connect to your AG directly. This is most useful if you want to put this shortcut in the startup folder or just to shave off those few seconds when opening the app.

Step 1: Click on Remote devices tab.

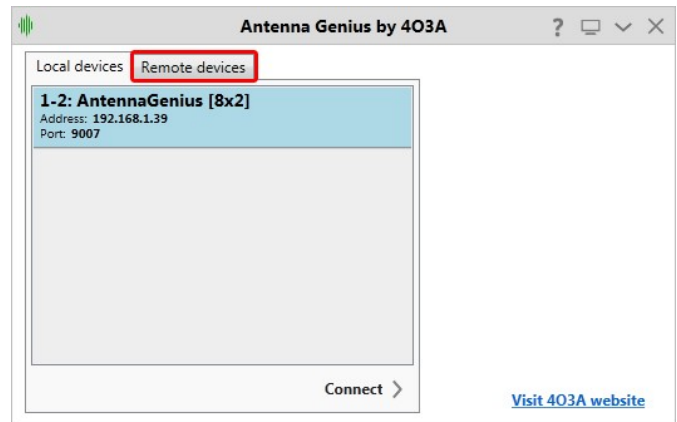

Step 2: Add an entry for your AG.

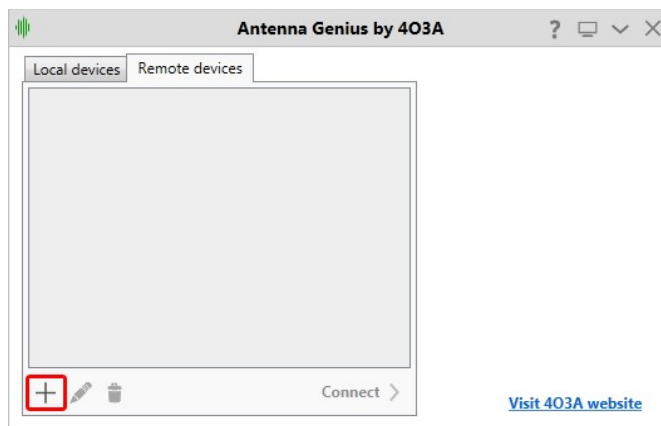

Step 3: Name it, enter the correct IP address. TCP port is most likely going to be the default 9007 value. Specify the mode you want to use. Click Save when done.

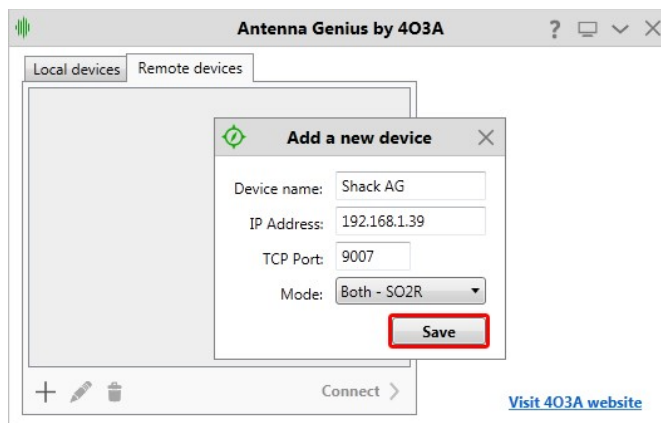

Step 4: Right click your AG shortcut and select Properties.

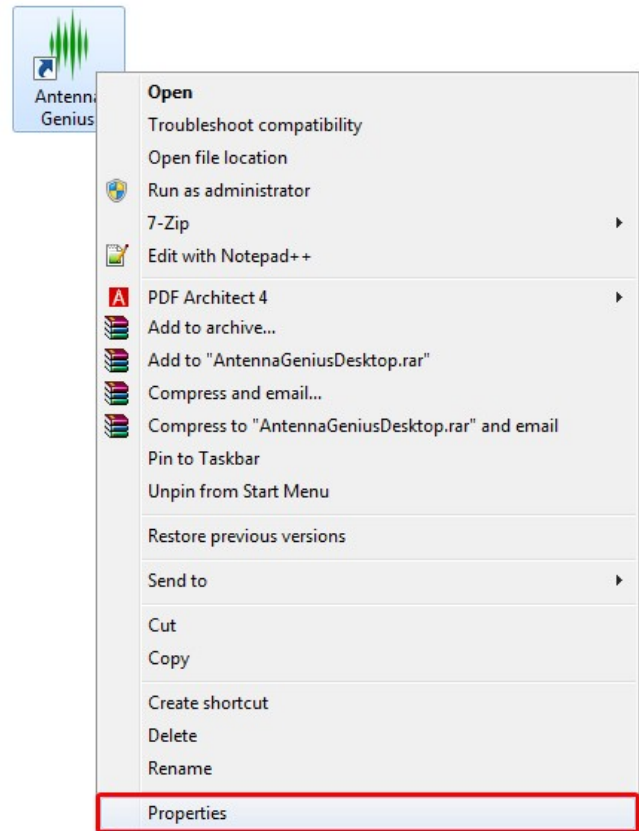

Step 5: In the target textbox, add -a1.

“-a” is the argument for connecting automatically.
“1” is the entry number. If you have only one remote entry use this. If you have multiple entries specify the one you want to connect to (2 for second entry, 3 for third etc.).

Click OK when done.

Next time you open the shortcut you will be automatically connected.

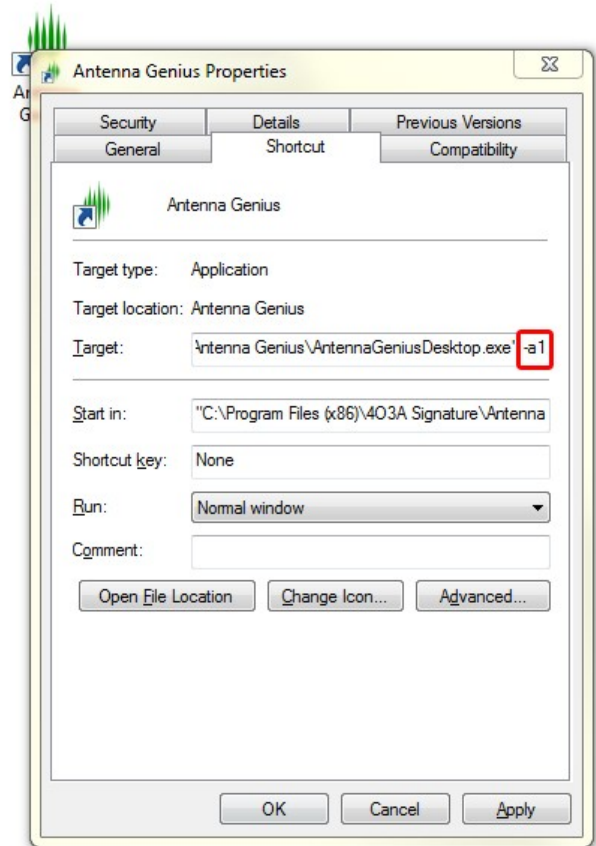

12. PHOTO GALLERY

AG port-to-port isolation second to none!



AG managing 3,200 W @ 28 MHz to dummy load without issue:

13. CHANGELOG

This log is not exhaustive, but covers the significant changes between versions.

Acronyms:

AG - Antenna Genius

App v3.0.4 Release 11-May-2017

Firmware version: v3.0.4

#010 The app now automatically detects the AG hardware model. 8x1 users won't get the "A/B/SO2R" option anymore.

App v3.0.3 Release 02-Feb-2017

Firmware version: v3.0.0

#009 Added the firmware file to the app.

#010 Added automatic discovery.

App v3.0.1 Release 08-Sep-2016

Firmware version: v3.0.0

#007 Fixed a bug regarding custom bands.

#008 Latest firmware file now comes included in the app installation, enabling easier firmware upgrades.

App v3.0.0 Release 31-Aug-2016

Firmware version: v3.0.0

▲ [Index](#)

52/53

#0004 Stacking: Ability to combine multiple 8x2 Plus AGs for 16x2, 24x2, and even 32x2 switching capability. Available only on the plus models.

#0005 Output Module Control: Ability to switch 16 accessory OM (Output Module) relays, available on the 8x1 Plus and 8x2 Plus models.

#0006 Three user programmable bands: can be any of range of frequencies supported by your transceiver, plus each of the ham band band edges can now also be user programmed.

App v2.0.2 Release 04-Apr-2016

Firmware version: v2.0.0

#0002 Application now accepts "-a<number>" command line argument for auto connecting on startup, skipping the main window.

Example: "AntennaGeniusDesktop.exe -a1" connects to the first item on the list, "AntennaGeniusDesktop.exe -a5" connects to the fifth item on the list, etc.

#0003 You can now import / export antenna configurations, making it easier to swap between setups.

App v2.0.1 Release 24-Mar-2016

Firmware version: v2.0.0

#0001 The app now reconnects to the FlexRadio after FlexRadio has been shut down and turned back on.

App v2.0.0 Release 11-Mar-2016

Firmware version: v2.0.0

This version is completely rewritten from scratch.

14.1. Known issues

#0001 When naming your antennas, make sure you don't leave the names blank. This will crash the device.